

ANNEX 16

RESOLUTION MEPC.66(37)

ADOPTED ON 14 SEPTEMBER 1995

**INTERIM GUIDELINES FOR APPROVAL OF ALTERNATIVE METHODS
OF DESIGN AND CONSTRUCTION OF OIL TANKERS UNDER
REGULATION 13F(5) OF ANNEX I OF MARPOL 73/78**

THE MARINE ENVIRONMENT PROTECTION COMMITTEE,

RECALLING Article 38(a) of the Convention on the International Maritime Organization concerning the functions of the Committee,

NOTING resolution MEPC.52(32) by which the Committee adopted new regulations 13F and 13G and related amendments to Annex I of MARPOL 73/78,

NOTING FURTHER resolution MEPC.52(32) by which the Committee agreed to develop, as a matter of urgency, Guidelines for approval of alternative methods of design and construction of oil tankers as called for in regulation 13F(5),

HAVING CONSIDERED, at its thirty-seventh session, the interim guidelines developed under regulation 13F(5) of Annex I of MARPOL 73/78,

1. **ADOPTS** the Interim Guidelines for Approval of Alternative Methods of Design and Construction of Oil Tankers under regulation 13F(5), the text of which is set out at Annex to this resolution;
2. **INVITES** Governments to give due consideration to the interim guidelines when evaluating other methods of design and construction of oil tankers as alternatives to the requirements prescribed in paragraph (3) of regulation 13F of Annex I of MARPOL 73/78, for submission of such design to the Committee for approval in principle;
3. **RESOLVES** to keep the interim guidelines under regulation 13F(5) under review and develop final guidelines in the light of experience gained.

ANNEX

**Interim Guidelines for the Approval of Alternative
Methods of Design and Construction of Oil
Tankers under Regulation 13F(5)
of Annex I of MARPOL 73/78**

Contents

	Page
Preamble	3
1. General	4
2. Applicability	4
3. Approval procedure for alternative tanker designs	5
4. Oil outflow analysis	5
4.1 General	5
4.2 Pollution prevention index	6
4.3 Calculation of oil outflow parameters	7
5. Assumptions for calculating oil outflow parameters	7
5.1 General	7
5.2 Damage assumptions	9
6. Probabilistic methodology for calculating oil outflow	12
6.1 Damage cases	12
6.2 Oil outflow calculations	12
7. Reference double hull designs	12
Figures 5 - 8	18-21

Preamble

1. The purpose of these Interim Guidelines hereunder referred to as the Guidelines is to provide an international standard for the evaluation and approval of alternative methods of designs and construction of oil tankers under regulation 13F(5) of Annex I of MARPOL 73/78.

2. The basic philosophy of the Guidelines is to compare the oil outflow performance in case of collision or stranding of an alternative tanker design to that of reference double hull designs complying with regulation 13F(3) on the basis of a calculated pollution prevention index.

The oil outflow performance of double hull tankers which comply with regulation 13F(3) may be different. The longitudinal subdivision of the cargo tanks has a major influence on the oil outflow in case of inner hull penetration. The selected reference double hull designs exhibit a favourable oil outflow performance.

3. The calculation of oil outflow is based on the probabilistic methodology and best available tanker accident damage statistics. Re-appraisal of the Guidelines may be appropriate when more information on tanker accident damage has become available and more experience with the application of these Guidelines has been gained.

4. Falling tides will have an adverse effect on oil outflow from a stranded tanker and the Guidelines take account of this. The tide values specified in Section 5 represent realistic average tidal changes which have been chosen to identify the influence of tidal changes on the oil outflow in case of stranding.

1. General

1.1 Regulation 13F of Annex I of OL 73/78 specifies structural requirements for new tankers of 600 tdw and above, contracted on or after 6 July 1993. Paragraph (3) of the regulation requires tankers of 5000 tdw and above to be equipped with double hulls. Various detailed requirements and permissible exceptions are given in the regulation.

Paragraph (5) of the regulation specifies that other designs may be accepted as alternatives to double hull, provided they give at least the same level of protection against oil pollution in the event of collision or stranding and are approved in principle by the MEPC based on Guidelines developed by the Organization

1.2 These Guidelines should be used to assess the acceptability of alternative oil tanker designs of 5000 tdw and above with regard to the prevention of oil outflow in the event of collision or stranding as specified in paragraph (5) of regulation 13F of Annex I of MARPOL 73/78.

1.3 For any alternative design of an oil tanker not satisfying regulation 13F (3) or (4) a study of the cargo oil outflow performance should be carried out as specified in Sections 4 through 6 of these Guidelines.

1.4 This study should cover the full range of ship sizes with a minimum of 4 different ship sizes, unless the approval is requested for only a limited range of vessel sizes. Data for 4 reference double hull designs are given in Section 7.

1.5 Evaluation of the cargo oil outflow performance of the proposed alternative design should be made by calculating the pollution prevention index "EII" as outlined in section 4 of these Guidelines.

1.6 The probabilistic methodology for the calculation of oil outflow according to these Guidelines is based on available tanker casualty statistics. With the collection of additional statistical material the damage density distribution functions specified in 5.2 should be periodically reviewed.

1.7 In principle, and as far as applicable, the requirements of paragraphs (3) (d) - (f) , (6) and (8) of regulation 13F apply also to alternative designs. The requirements of paragraph (9) of regulation 13F also apply to alternative designs. In addition, it should be demonstrated by means of a risk analysis that the new design under consideration provides an adequate safety level. Such analysis should address any specific risks associated with the alternative design, and if there are any, it should be demonstrated that safe solutions exist to cope with them.

2. Applicability

2.1 These Guidelines apply to the assessment of alternative designs of oil tankers to be constructed of steel or other equivalent material as required by regulation 42 of chapter II-2 of the 1974 SOLAS Convention as amended. Designs for tankers intended to be constructed of other materials or incorporating novel features (e.g. non-metallic materials), or designs which use impact absorbing devices should be specially considered

2.2 The approval procedure of these Guidelines applies to oil tankers of sizes up to 350000 tdw. For larger sizes the approval procedure should be specially considered.

3. Approval procedure for alternative tanker designs

3.1 An Administration of a Party to MARPOL 73/78, which receives a request for approval of an alternative tanker design for the purpose of complying with regulation 13F, should first evaluate the proposed design and satisfy itself that the design complies with these Guidelines and other applicable regulations of Annex I of MARPOL 73/78. That Administration should then submit the proposal and the supporting documentation together with its own evaluation report to the Organization for evaluation and approval of the design concept by the Marine Environment Protection Committee (MEPC) as an alternative to the requirements of regulation 13F(3). Only design concepts which have been approved in principle by the MEPC are allowed for the construction of tankers to which regulation 13F(S) applies.

3.2 The submission to the Administration and the Organization should at least include the following items:

- .1 Detailed specification of the alternative design concept.
- .2 Drawings showing the basic design of the tank system and, where necessary, of the entire ship.
- .3 Study of the oil outflow performance as outlined in paragraphs 1.3 - 1.5.
- .4 Risk analysis as outlined in paragraph 1.7.
- .5 Details of the calculation procedure or computer program used for the probabilistic oil outflow analysis to satisfy the Administration that the calculation procedure used gives satisfactory results. For verification of the computer program see paragraph 6.2.

Any additional information may be required to be submitted if deemed necessary.

3.3 In addition to the approval procedure for the design concept specified in 3.1 and 3.2 above, the final shipyard design should be approved by the Flag State Administration for compliance with these Guidelines and all other applicable regulations of Annex I of MARPOL 73/78. This should include survivability considerations as referred to in 5.1.5.10.

3.4 Any approved design concept will require reconsideration if the guidelines have been amended.

4. Oil outflow analysis

4.1 General

4.1.1 The oil pollution prevention performance of a tanker design is expressed by a non-dimensional oil pollution prevention index "E" which is a function of the three oil outflow parameters "probability of zero outflow", "mean outflow" and "extreme outflow". The oil outflow parameters should be calculated for all conceivable damage cases within the entire envelop of damage conditions as detailed in Section 5.

4.1.2 The three oil outflow parameters are defined as follows:

Parameter for probability of zero oil outflow. This parameter represents the probability that no cargo oil will escape from the tanker in case of collision or stranding. If, e.g. the parameter equals 0.6, in 60% of all collision or stranding accidents no oil outflow is expected to occur.

Mean oil outflow parameter. The mean oil outflow represents the sum of all outflow volumes multiplied by their respective probabilities. The mean oil outflow parameter is expressed as a fraction of the total cargo oil capacity at 98% tank filling.

Extreme oil outflow parameter. The extreme oil outflow is calculated - after the volumes of all outflow cases have been arranged in ascending order - as the sum of the outflow volumes between 0.9 and 1.0 cumulative probability, multiplied by their respective probabilities. The value so derived is multiplied by 10. The extreme oil outflow parameter is expressed as a fraction of the total cargo oil capacity at 98% tank filling.

4.1.3 In general, consideration of ship's survivability will not be required for the conceptual approval of an alternative design. This may, however, be required in special cases depending on special features of the design.

4.2 Pollution prevention index

The level of protection against oil pollution in the event of collision or stranding as compared to the reference double hull designs should be determined by calculation of the pollution prevention index "E" as follows:-

$$E = k_1 \frac{P_O}{P_{OR}} + k_2 \frac{0.01 + O_{MR}}{0.01 + O_M} + k_3 \frac{0.025 + O_{ER}}{0.025 + O_E} \geq 1.0$$

k_1 , k_2 and k_3 are weighting factors having the values:

$$k_1 = 0.5$$

$$k_2 = 0.4$$

$$k_3 = 0.1$$

where:

P_O = parameter for probability of zero oil outflow for the alternative design

O_M = mean oil outflow parameter for the alternative design

O_E = extreme oil outflow parameter for the alternative design

P_{OR} , O_{MR} and O_{ER} are the corresponding parameters for the reference double hull design of the same cargo oil capacity as specified in Section 7.

4.3 Calculation of oil outflow parameters

The oil outflow parameters P_0 , O_M and O_E should be calculated as follows:

Parameter for probability of zero outflow P_0 :

$$P_0 = \prod_{i=1}^n P_i \cdot K_i$$

where:

"i" represents each compartment or group of compartments under consideration running from $i=1$ to $i=n$

" P_i " accounts for the probability that only the compartment or group of compartments under consideration are breached

" K_i " equals 0 if there is oil outflow from any of the breached cargo spaces in "i". If there is no outflow, " K_i " equals 1.

Mean outflow parameter " O_M ":

$$O_M = \sum_{i=1}^n \frac{P_i \cdot O_i}{C}$$

where:

" O_i " = combined oil outflow (m^3) from all cargo spaces breached in "i"

C = total cargo oil capacity at 98% tank filling (m^3)

Extreme outflow parameter " O_E ":

$$O_E = 10 \left(\sum \frac{P_{ie} \cdot O_{ie}}{C} \right)$$

where the index "ie" represents the extreme outflow cases which are the damage cases falling within the cumulative probability range between 0.9 and 1.0, after they have been arranged as specified in 6.1.

5. Assumptions for calculating oil outflow parameters

5.1 General

5.1.1 The assumptions specified in this Section should be used when calculating the oil outflow parameters.

5.1.2 Outflow parameters should be calculated independently for collisions and strandings and then combined as follows:

0.4 of the computed value for collisions plus

0.6 of the computed value for strandings.

5.1.3 For strandings, independent calculations should be done for 0 metre, 2 metre and 6 metre tide. The tide, however, need not be taken greater than 50% of the ship's maximum draught. Outflow parameters for the stranded conditions should be a weighted average calculated as follows:

0.4 for 0 m tide condition

0.5 for minus 2 m tide condition

0.1 for minus 6 m tide condition.

5.1.4 The damage cases and the associated probability factor " P_i " for each damage case should be determined based on the damage density distribution functions as specified in paragraph 5.2.

5.1.5 The following general assumptions apply for the calculation of outflow parameters:

- .1 The ship should be assumed to be loaded to the maximum assigned loadline with zero trim and heel and with a cargo having a density allowing all cargo tanks to be filled to 98%.
- .2 For all cases of collision damage the entire contents of all damaged cargo oil tanks should be assumed to be spilled into the sea, unless proven otherwise.
- .3 For all stranded conditions, the ship should be assumed aground on a shelf. Assumed stranded draughts prior to tidal change should be equal to the initial intact draughts. Should the ship trim or float free due to the outflow oil, this should be accounted for in the calculations for the final shipyard design.
- .4 In general, an inert gas overpressure of 0.05 bar gauge should be assumed.
- .5 For the calculation of oil outflow in case of stranding the principles of hydrostatic balance should apply, and the location of damage used for calculations of hydrostatic pressure balance and related oil outflow calculations should be the lowest point in the cargo tank.

- .6 For cargo tanks bounded by the bottom shell, unless proven otherwise, oil outflow equal to 1% of the volume of the damaged tank should be assumed to account for initial exchange losses and dynamic effects due to current and waves.
- .7 For breached non-cargo spaces located wholly or in part below breached cargo oil tanks, the flooded volume of these spaces at equilibrium should be assumed to contain 50% oil and 50% seawater by volume, unless proven otherwise.
- .8 If deemed necessary, model tests may be required to determine the influence of tidal, current and swell effects on the oil outflow performance.
- .9 For ship designs which incorporate cargo transfer systems for reducing oil outflow, calculations should be provided illustrating the effectiveness of such devices. For these calculations, damage openings consistent with the damage density distribution functions defined in 5.2 should be assumed.
- .10 Where, for the final shipyard design referred to in 3.3. and in the special cases referred to 4.1.3, damage stability calculations are required, the following should apply:

A damage stability calculation should be performed for each damage case. The stability in the final stage of flooding should be regarded as sufficient if the requirements of regulation 25(3) of Annex I of MARPOL 73/78 are complied with.

Should the ship fail to meet the survivability criteria as defined in regulation 25(3), 100% oil outflow from all cargo tanks should be assumed for that damage case.

5.2 Damage assumptions

5.2.1 General, Definitions

The damage assumptions for the probabilistic oil outflow analysis are given in terms of damage density distribution functions specified in subparagraphs 5.2.2 and 5.2.3. These functions are so scaled that the total probability for each damage parameter equals 100%, i.e. the area under each curve equals 1.0.

The location of a damage refers always to the centre of a damage. Damage location and extent to an inner horizontal bottom or vertical bulkhead should be assumed to be the same as the statistically derived damage to the outer hull.

The location and extent of damage to compartment boundaries should be assumed to be of rectangular shape following the hull surface in the extents defined in subparagraphs 5.2.2 and 5.2.3.

The following definitions apply for the purpose of subparagraphs 5.2.2 and 5.2.3.

- x = dimensionless distance from A.P. relative to the ship's length between perpendiculars
- y = dimensionless longitudinal extent of damage relative to the ship's length between perpendiculars
- z_t = dimensionless transverse penetration extent relative to the ship's breadth
- z_v = dimensionless vertical penetration extent relative to the ship's depth
- z_1 = dimensionless vertical distance between the baseline and the centre of the vertical extent z_v relative to the distance between baseline and deck level (normally the ship's depth)
- b = dimensionless transverse extent of bottom damage relative to the ship's breadth
- b_1 = dimensionless transverse location of bottom damage relative to the ship's breadth.

5.2.2 Side damage due to collision

Function for longitudinal location:

$$f_{s1} = 1.0 \quad \text{for } 0 \leq x \leq 1.0$$

$$f_{s2} = 11.95 - 84.5y \quad \text{for } y \leq 0.1$$

$$f_{s2} = 6.65 - 31.5y \quad \text{for } 0.1 \leq y \leq 0.2$$

$$f_{s2} = 0.35 \quad \text{for } 0.2 \leq y \leq 0.3$$

function for transverse penetration:

$$\begin{aligned} f_{13} &= 24.96 - 399.2z_1 & \text{for } z_1 &\leq 0.05 \\ f_{13} &= 9.44 - 88.8z_1 & \text{for } 0.05 < z_1 &\leq 0.1 \\ f_{13} &= 0.56 & \text{for } 0.1 < z_1 &\leq 0.3 \end{aligned}$$

function for vertical extent:

$$\begin{aligned} f_{14} &= 3.83 - 11.1z_v & \text{for } z_v &\leq 0.3 \\ f_{14} &= 0.5 & \text{for } z_v &> 0.3 \end{aligned}$$

function for vertical location:

$$\begin{aligned} f_{15} &= z_1 & \text{for } z_1 &\leq 0.25 \\ f_{15} &= 5z_1 - 1.0 & \text{for } 0.25 < z_1 &\leq 0.50 \\ f_{15} &= 1.50 & \text{for } 0.50 < z_1 &\leq 1.00 \end{aligned}$$

Graphs of the functions f_{11} , f_{12} , f_{13} , f_{14} and f_{15} are shown in Figures 1 and 2.

5.2.3 Bottom damage due to stranding

Function for longitudinal location:

$$\begin{aligned} f_{b1} &= 0.2 + 0.8x & \text{for } x &\leq 0.5 \\ f_{b1} &= 4x - 1.4 & \text{for } 0.5 < x &\leq 1.0 \end{aligned}$$

function for longitudinal extent:

$$\begin{aligned} f_{b2} &= 4.5 - 13.33y & \text{for } y &\leq 0.3 \\ f_{b2} &= 0.5 & \text{for } 0.3 < y &\leq 0.8 \end{aligned}$$

function for vertical penetration

$$\begin{aligned} f_{b3} &= 14.5 - 134z_v & \text{for } z_v &\leq 0.1 \\ f_{b3} &= 1.1 & \text{for } 0.1 < z_v &\leq 0.3 \end{aligned}$$

function for transverse extent:

$$\begin{aligned} f_{b4} &= 4.0 - 12b & \text{for } b &\leq 0.3 \\ f_{b4} &= 0.4 & \text{for } 0.3 < b &\leq 0.9 \\ f_{b4} &= 12b - 10.4 & \text{for } b &> 0.9 \end{aligned}$$

function for transverse location:

$$f_{b5} = 1.0 \quad \text{for } 0 \leq b_1 \leq 1.0$$

Graphs of the functions f_{b1} , f_{b2} , f_{b3} , f_{b4} and f_{b5} are shown in Figures 3 and 4.

6. Probabilistic methodology for calculating oil outflow

6.1 Damage cases

6.1.1 Using the damage probability distribution functions specified in paragraph 5.2, all damage cases "n" as per paragraph 4.3 should be evaluated and placed in ascending order of oil outflow. The cumulative probability for all damage cases should be computed, being the running sum of probabilities beginning at the minimum outflow damage case and proceeding to the maximum outflow damage case. The cumulative probability for all damage cases should be 1.0.

6.1.2 For each damage case the damage consequences in terms of penetrations (breaching) of cargo tank boundaries should be evaluated and the related oil outflow calculated. A cargo tank should be considered as being breached in a damage case under consideration if the applied damage envelope reaches any part of the cargo tank boundaries.

6.1.3 When determining the damage cases, it should be assumed for the purpose of these calculations that the location, extent and penetration of damages are independent of each other.

6.2 Oil outflow calculations

6.2.1 The probabilistic oil outflow calculations may be done as outlined by the "Example for the Application of the Interim Guidelines" given in the Appendix to these Guidelines. Other calculation procedures may be accepted, provided they show acceptable accuracy.

6.2.2 The computer program used for the oil outflow analysis should be verified against the data for oil outflow parameters for the reference double hull designs given in section 7.

6.2.3 After the final waterline has been determined, the oil outflow from each damaged cargo tank should be computed for each damage case under the assumptions specified in 5.1.5.

7. Reference double hull designs

Data for four reference double hull designs of 5000 tdw, 60000 tdw, 150000 tdw and 283000 tdw are summarized in Tables 7.1 and 7.2 and are illustrated in Figures 5 - 8.

Table 7.1 contains the data for the oil outflow parameters P_{OR} , O_{MR} and O_{ER} to be used for the concept approval (ship survivability not considered). Table 7.2 contains the corresponding data to be used for the shipyard design approval (ship survivability considered).

Table 7.1

Ref. Design No.	Deadweight DW(t)	Oil Outflow Parameters (ship survivability not considered)		
		P _{OR}	O _{MR}	O _{ER}
1	5000	.81	.017	.127
2	60000	.81	.014	.104
3	150000	.79	.016	.113
4	283000	.77	.013	.085

Table 7.2

Ref. Design No.	Deadweight DW(t)	Oil Outflow Parameters (ship survivability considered)		
		P _{OR}	O _{MR}	O _{ER}
1	5000	.72	.113	.469
2	60000	.81	.021	.173
3	150000	.79	.017	.124
4	283000	.77	.015	.098

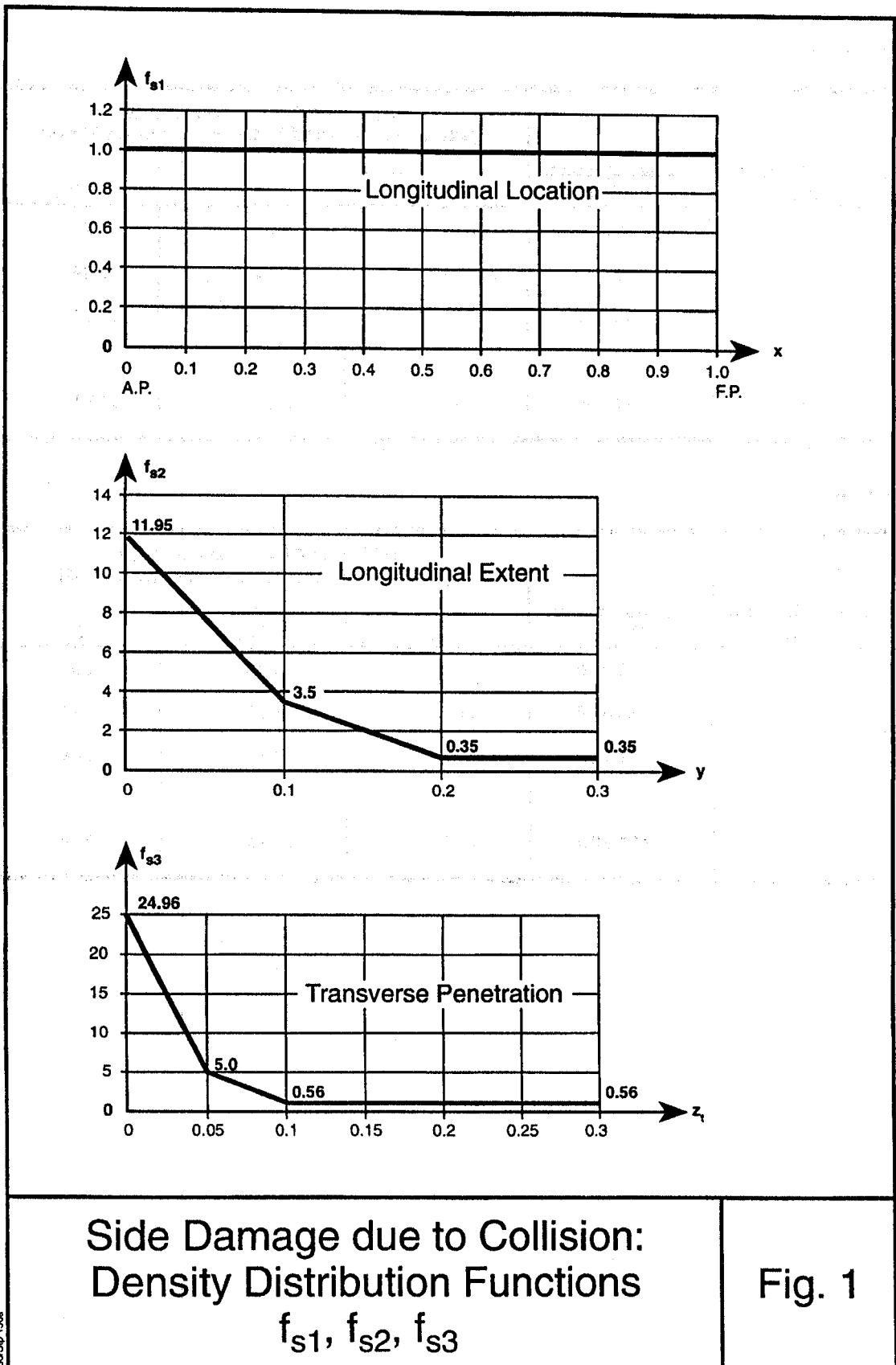

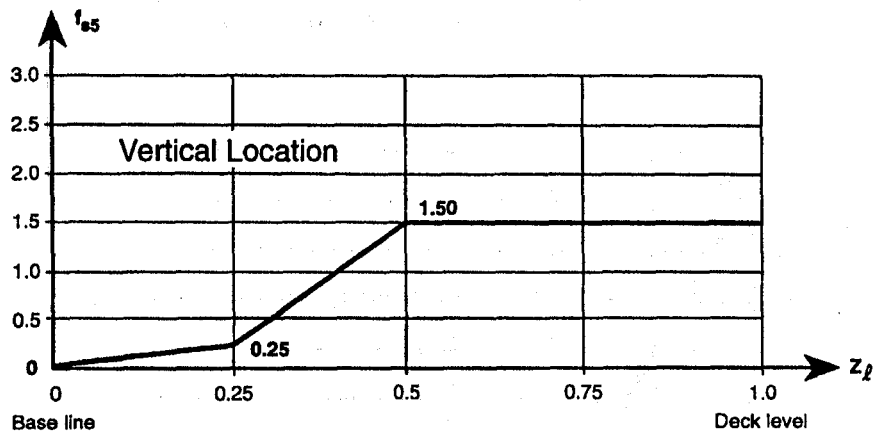
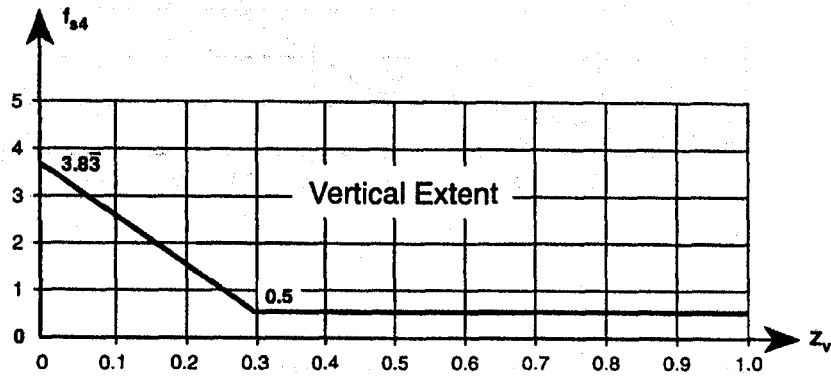

Side Damage due to Collision:
 Density Distribution Functions
 f_{s4} and f_{s5}

Fig. 2

20/Sp. 965a

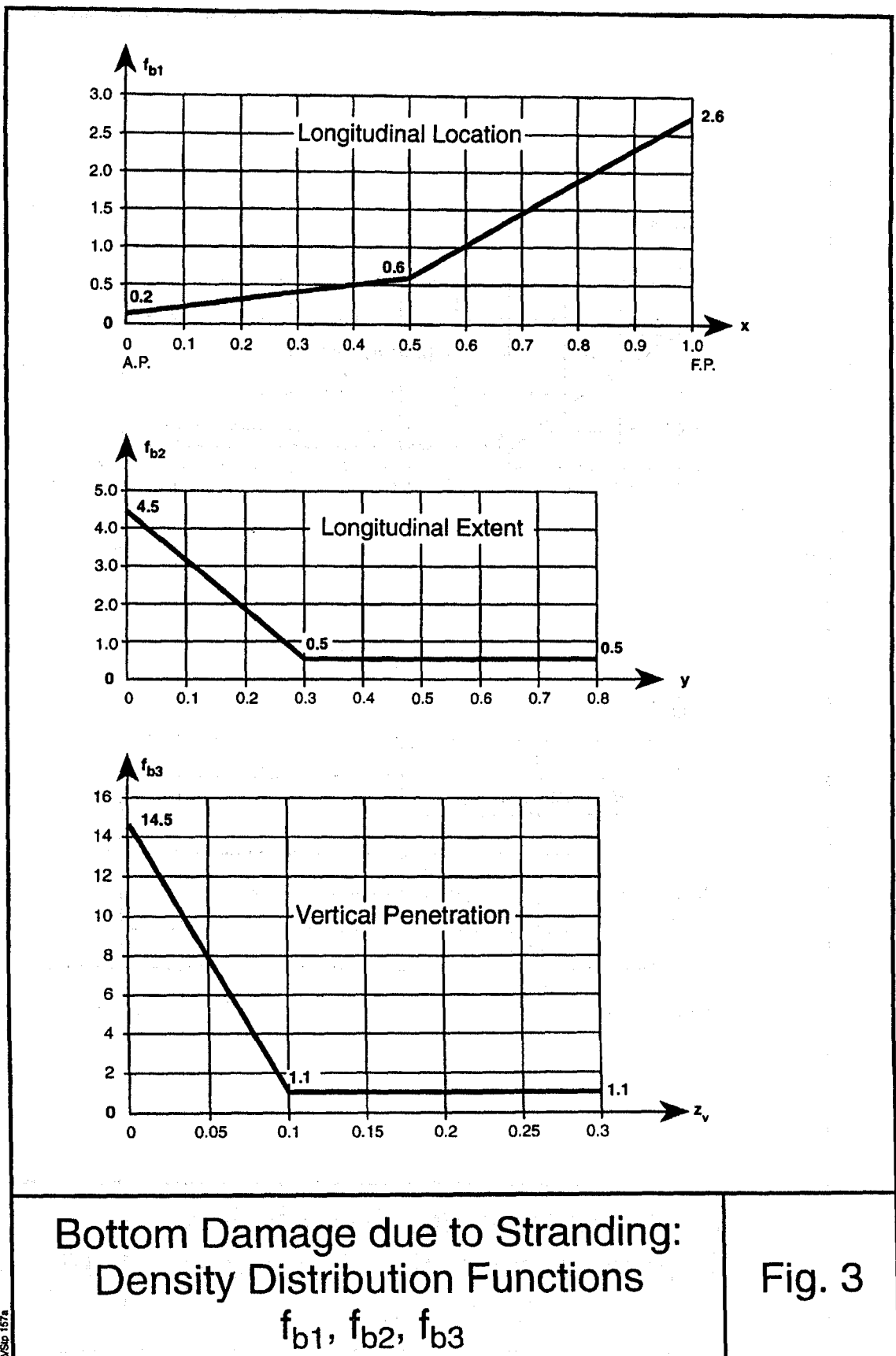
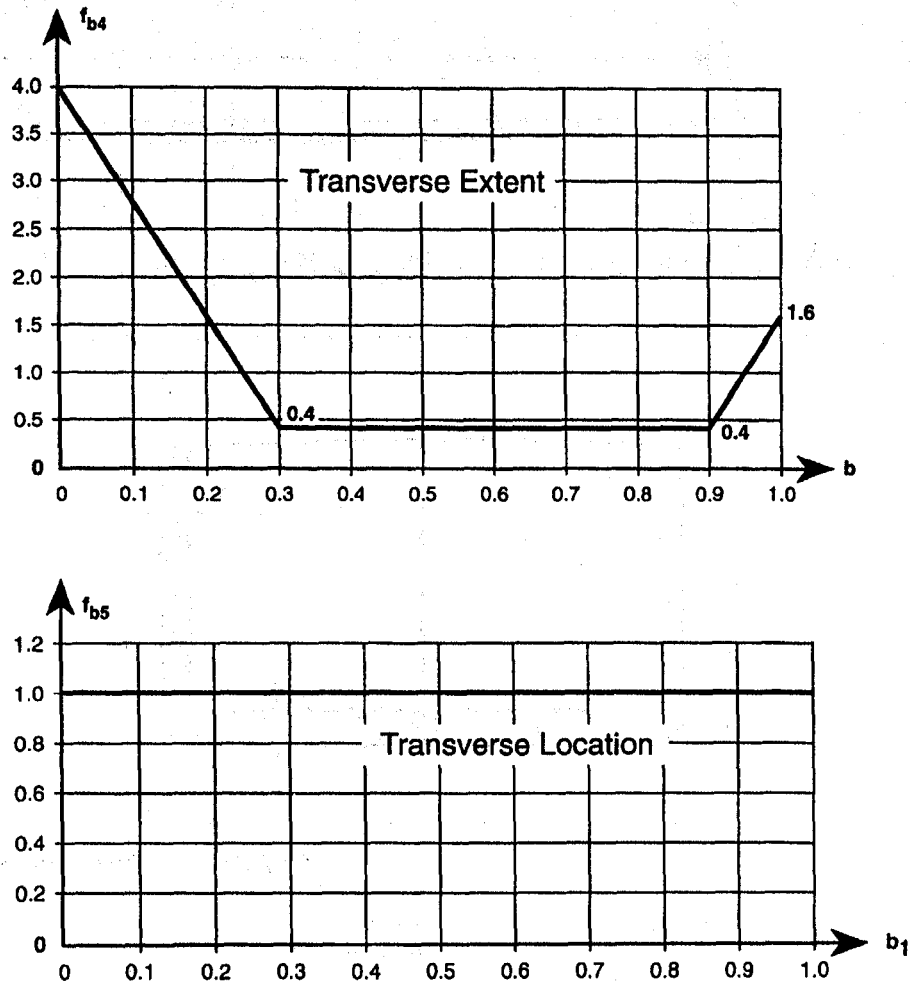

Fig. 3



Bottom Damage Density
Distribution Function
 f_{b4} and f_{b5}

Fig. 4

80/Sip 672a

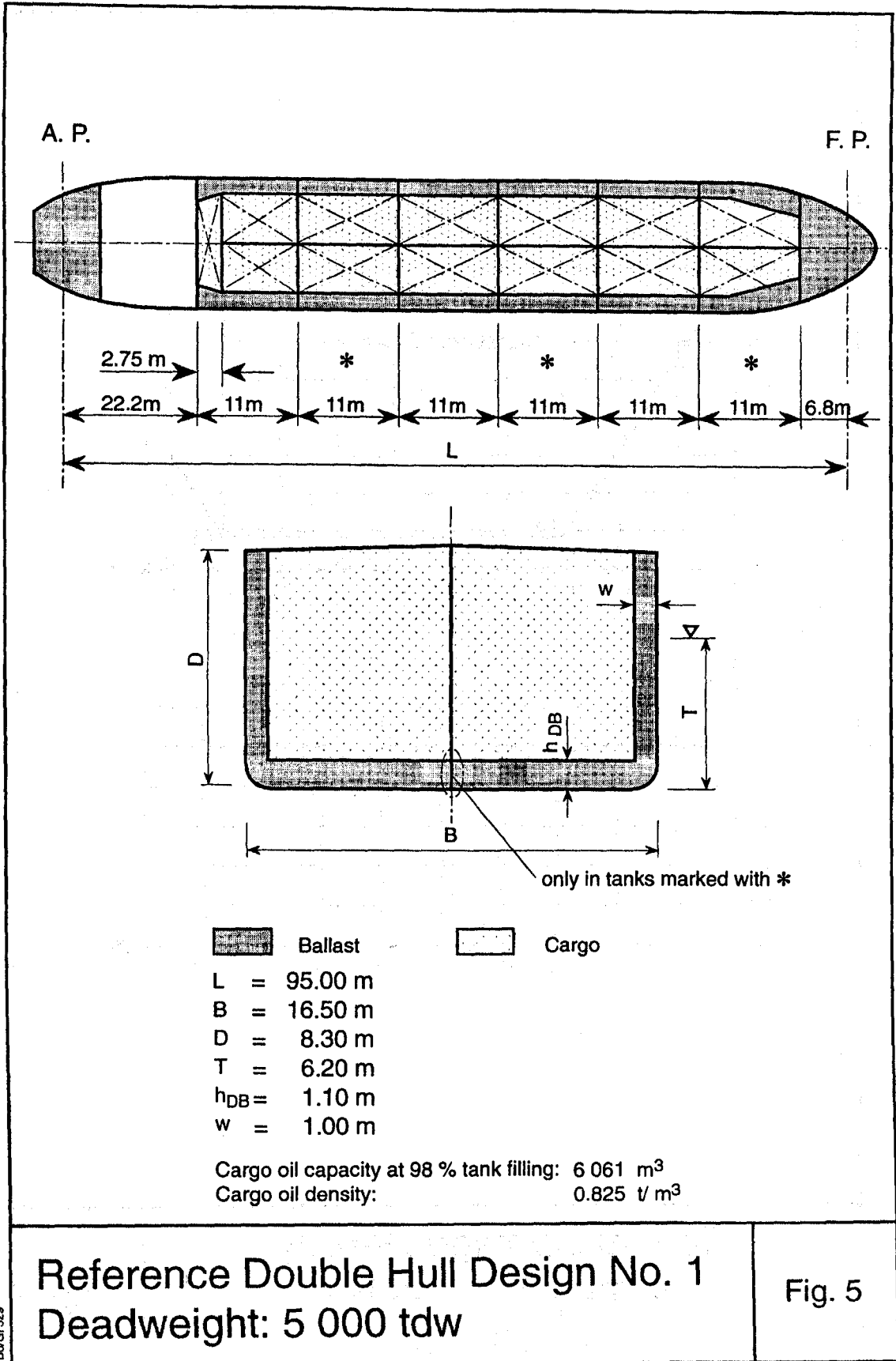

B0/GI/329

Fig. 5

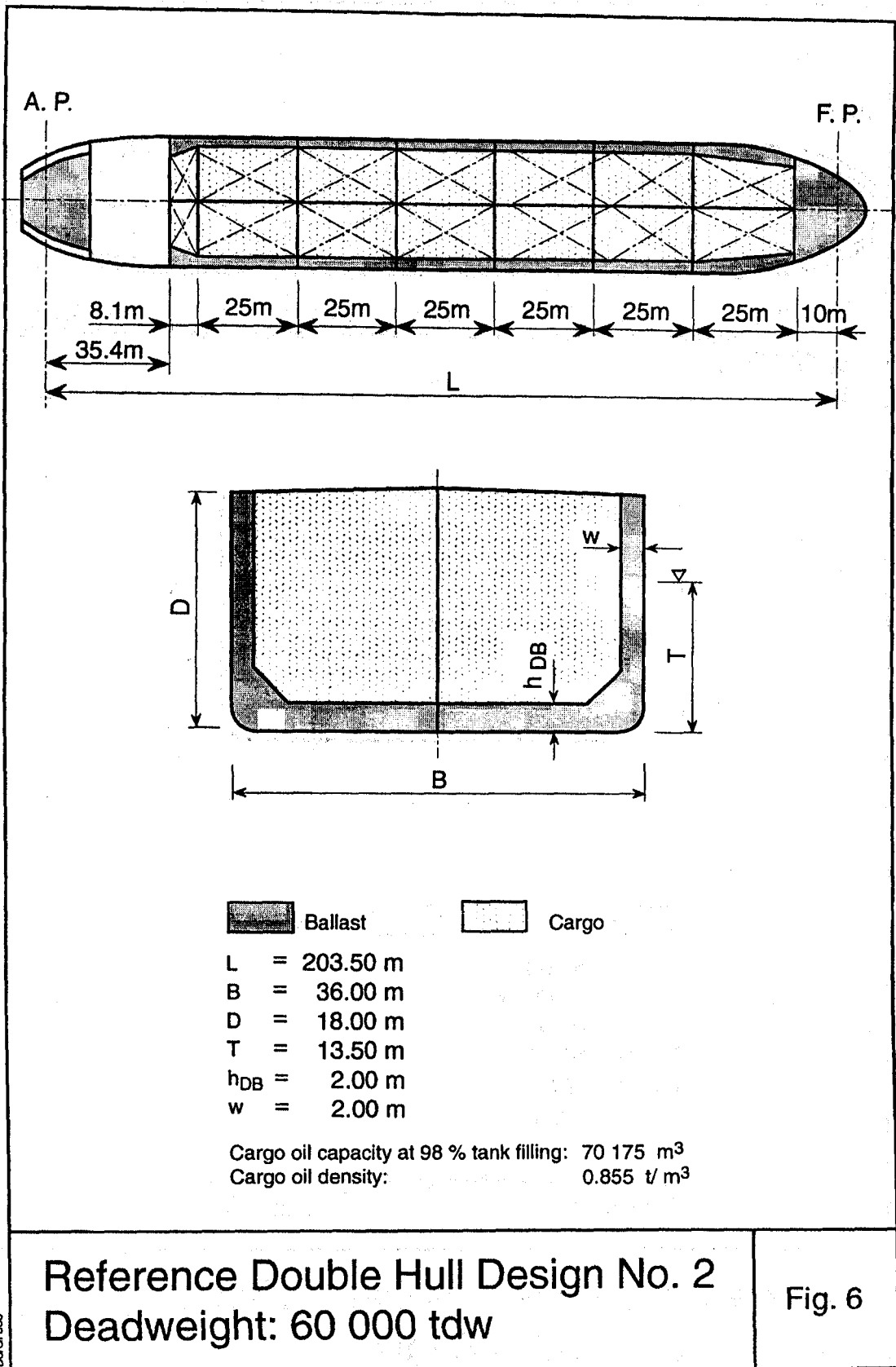
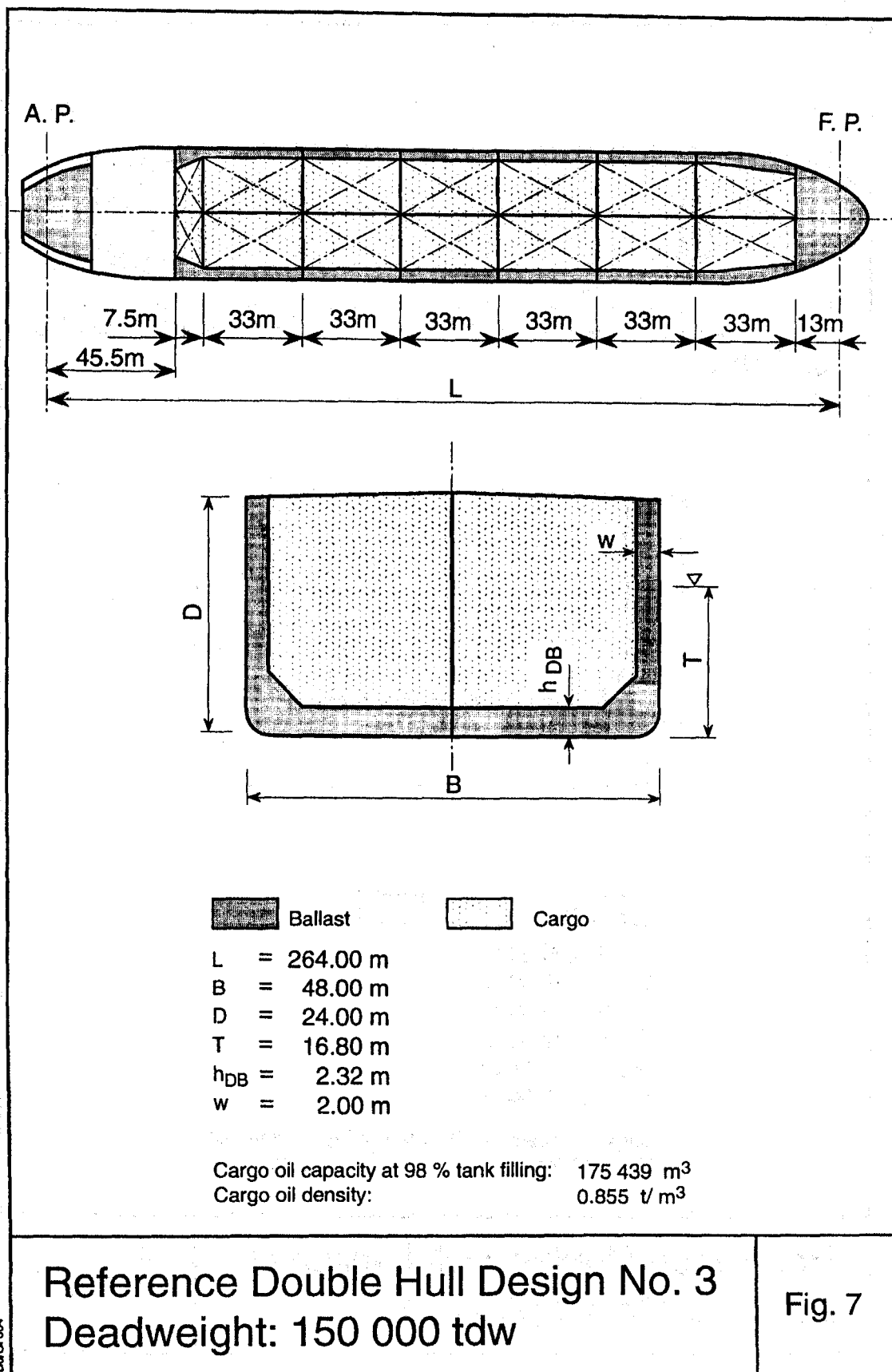

Fig. 6



86/GI 334

Reference Double Hull Design No. 3
 Deadweight: 150 000 tdw

Fig. 7

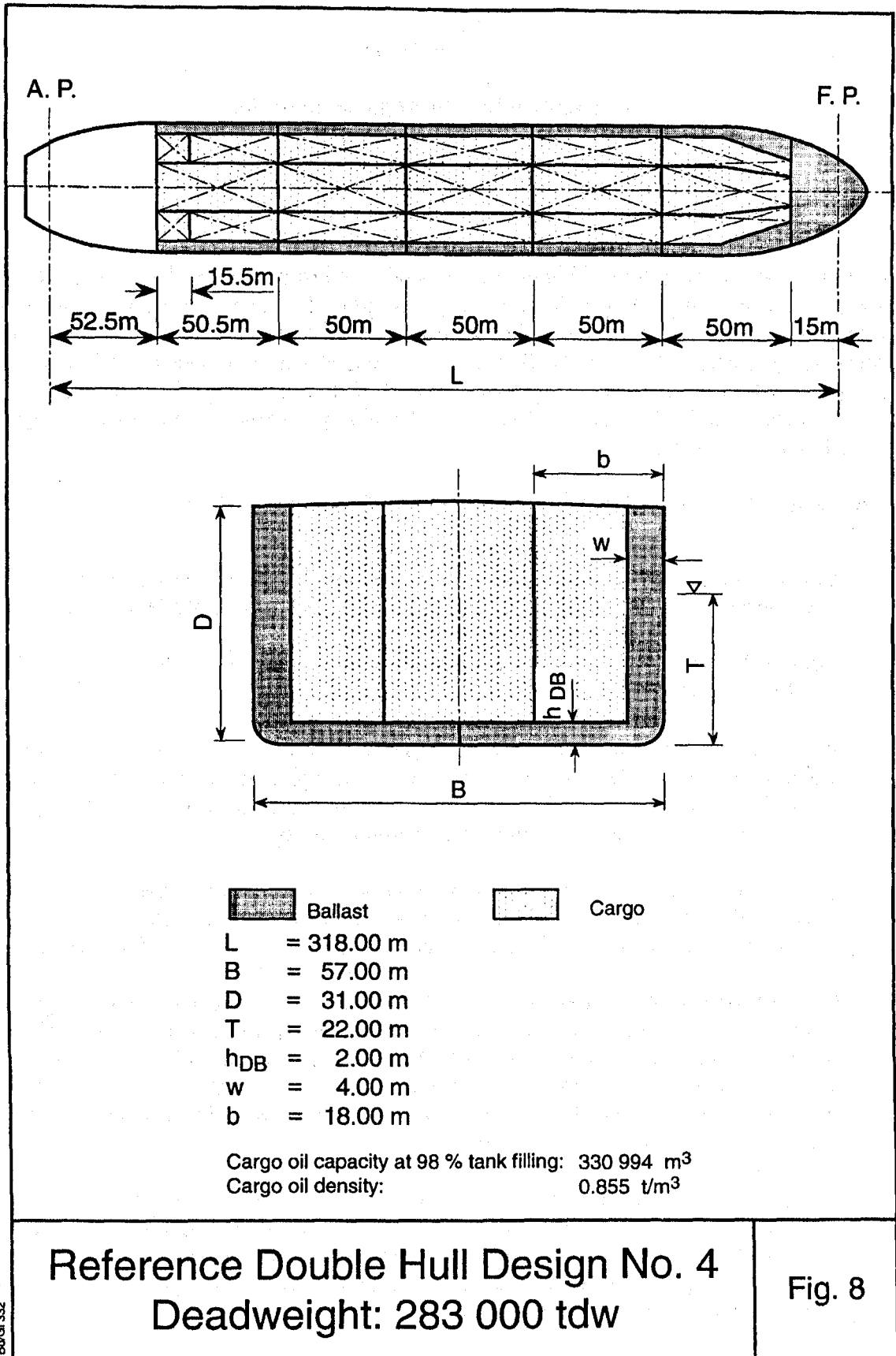

APPENDIX

Example for the Application of the "Interim Guidelines"

1. General

The application of the Interim Guidelines, hereunder referred to as Guidelines, is shown in the following worked example illustrating the calculation procedure of the oil outflow parameters for a tank barge. For presentation purposes, a simplified hull form and level of compartmentation have been assumed. The procedures described herein are readily adaptable as a computer application, which will be necessary as more complicated arrangements are evaluated. This example is evaluated in accordance with the requirements for "concept approval". Additional requirements for a shipyard design approval are noted where applicable.

An application of the Guidelines will typically follow these seven basic steps:

- 1) **Vessel design:** In accordance with paragraph 3.1 of the Guidelines, the vessel is designed to meet all applicable regulations of Annex I of MARPOL 73/78.
- 2) **Establishing of the full load condition:** In accordance with paragraph 5.1.5 of the Guidelines, a full load condition is developed.
- 3) **Assembling of the damage cases:** By applying the damage density distribution functions provided in the Guidelines, determine each unique grouping of damaged compartments and the probability associated with that damage condition. Independent sets of damage cases are derived for side (collision) and bottom (stranding) damage.
- 4) **Computation of the equilibrium condition for each damage case:** Compute the final equilibrium condition for all side and bottom damage conditions. This step is only required for the final shipyard design, in accordance with paragraph 5.1.5.10 of the Guidelines.
- 5) **Computation of the oil outflow for each damage case:** Calculate the oil outflow for each damage case. Separate calculations are done for side damage, and for bottom damage at the 0,0 m, 2,0 m and 6,0 m tide conditions. For side damage, all oil is assumed to escape from damaged tanks. For bottom damage, a hydrostatic balance method is applied. For the final shipyard design, survivability is evaluated in accordance with the requirements of regulation 25(3) of Annex I of MARPOL 73/78.
- 6) **Computation of the oil outflow parameters:** The cumulative probability of occurrence of each level of oil outflow is developed. This is done for the side damage and for each bottom damage tide condition. The associated oil outflow parameters are then computed. The bottom damage tidal parameters are combined in accordance with paragraph 5.1.3, and the side and bottom damage parameters are then combined in accordance with paragraph 5.1.2, of the Guidelines.

- 7) **Computation of the Pollution Prevention Index "E"**: The new design has satisfactory characteristics if "E" as defined in paragraph 4.2 of the Guidelines is greater than or equal to 1,0.

2. Analysis procedure

The basic steps Nos. 1 through 6 are described in this Section.

2.1 Step 1: Vessel design

The arrangement and dimensions of the example barge are as shown in Figure A1. (Barge Arrangement). For clarity purposes, a simple arrangement has been selected which does not meet all MARPOL 73/78 requirements. However, for actual designs submitted for approval as an alternative to double hull, the vessel must meet all applicable regulations of Annex I of MARPOL 73/78.

2.2 Step 2: Establishing of the full load condition

An intact load condition shall be developed with the vessel at its maximum assigned loadline with zero trim and heel. Departure quantities of constants and consumables (fuel oil, diesel oil, fresh water, lube oil, etc.) should be assumed. Capacities of cargo oil tanks should be based on actual permeability's for these compartments. All cargo oil tanks shall be assumed to be filled to 98% of their capacities. All cargo oil shall be taken at a homogenous density.

For this example, it is assumed that the permeability of the cargo oil tanks is 0,99 and 0,95 for the double bottom/wing tank ballast spaces. The 100% capacity of the cargo oil tanks CO1 and CO2 is:

CO1:	9 623 m ³
CO2:	28 868 m ³
Total:	38 491 m ³ .

Cargo tank capacity at 98 % filling: $C = 0,98 \cdot 38491 = 37721 \text{ m}^3$.

For this barge, for simplicity reasons, zero weight for the constants and consumables has been assumed. At the 9,0 m assigned load line the following values for the cargo oil mass W and density ρ_c are obtained:

$$W = \text{displacement} - \text{light barge weight} = 33\,949 \text{ t}$$

$$\rho_c = 33\,949 \text{ t} / C = 0,90 \text{ t} / \text{m}^3.$$

2.3 Step 3: Assembling of the damage cases

In this step the damage cases have to be developed. This involves applying the probability density distributions functions for side damage (Figures 1 and 2) and the probability density distribution functions for bottom damage (Figures 3 and 4). Each unique grouping of damaged compartments is determined together with its associated probability. The sum of the probabilities should equal 1,0 for both the side and the bottom damage evaluations.

There are different methods available for developing the compartment groupings and probabilities, each of which should converge on the same results.

In this example, the compartment groupings and the use of the probability density functions is shown by a "step-wise" evaluation method. This method involves stepping through each damage location and extent at a sufficiently fine increment. For instance, it is assumed (for the side damage) to step through the functions as follows: longitudinal location = 100 steps, longitudinal extent = 100 steps, transverse penetration = 100 steps, vertical location = 10 steps, and vertical extent = 100 steps. You will then be developing 10^9 damage incidents. The probability of each step is equal to the area under the probability density distribution curve over that increment. The probability for each damage incident is the product of the probabilities of the five functions. There are many redundant incidents which damage identical compartments. These are combined by summing their probabilities. For a typical double hull tanker, the 10^9 damage incidents reduce down to 100 to 400 unique groupings of compartments.

2.3.1 Side damage evaluation

The damage density distribution functions provide independent statistics for location, length, and penetration. For side damage, the probability of a given damage longitudinal location, longitudinal extent, transverse penetration, vertical location and vertical extent is the product of the probabilities of these five damage characteristics.

To maintain the example at a manageable size, fairly coarse increments have been assumed:

Longitudinal location at 10 steps:	=	$L/10$	=	$0,10L$	per step
Longitudinal extent at 3 steps:	=	$0,3L/3$	=	$0,10L$	per step
Transverse penetration at 6 steps:	=	$0,3B/6$	=	$0,05B$	per step.

To further simplify the evaluation, each damage is assumed to extend vertically without limit. Therefore, the probability of vertical location and vertical extent are taken as 1,0 for each damage case. This is a reasonable assumption as the double bottom height is only 10% of the depth. Taking the area under the density distribution function for vertical location up to $0,1D$ (see Figure 2, function fs5) yields a value of 0,005. This means that the probability of the centre of damage location falling within the double bottom region is $1/200$.

Figure A2 (Side Damage Definition) shows the steps for longitudinal location, longitudinal extent and transverse penetration in relation to the barge. Table A1 (Increments for Step-wise Side Damage Evaluation) gives the range for each step, the mean or average value over the step, and the probability of occurrence of that particular step. For instance, Z_1 covers the range of transverse penetration beginning at the side shell and extending inboard 5% of the breadth. The average penetration is $0,025B$ or 2,5% of the breadth. The probability of occurrence is the likelihood that the penetration will fall within the range of 0% - 5% of the breadth. The probability equals 0,749, which is the area under the density distribution function for transverse penetration (Figure 1 function fs3) between $0,0B$ and $0,05B$. The area under each probability density function is 1,0, and therefore the sum of the probabilities for all increments for each function is 1,0.

A total of ten longitudinal locations, three longitudinal extents and six transverse penetrations will be evaluated. All combinations of damages must be considered for a total of $(10)(3)(6) = 180$ separate incidents. The damaged compartments are found by overlaying each combination of location/extent/penetration onto the barge. These damage boundaries define a rectangular box. Any compartment which extends into this damage zone is considered damaged. Each of the 180 incidents results in damage to one or more compartments. Incidents with identical damaged compartments are collected into a single damage case by summing the probabilities of the individual damage incidents.

Let us begin at the aft end of the barge and proceed forward. The first damage location X_1 is centred 0,05L forward of the transom. The first damage extent Y_1 has an average length of 0,05L. The average value for the first transverse penetration Z_1 is 0,025B. The resulting damage box lies entirely within the WB1 compartment and therefore damages that compartment only. The probability of this incident is:

$$P_{111} (X_1 Y_1 Z_1) = (0,1000)(0,7725)(0,7490) = 0,05786$$

If we step through the transverse penetrations Z_2 through Z_6 , we find that only the WB1 compartment is damaged for each of these cases. The probabilities for these cases are 0,01074, 0,00216, 0,00216, 0,00216, 0,00216, and 0,00216 respectively. The combined probability for the six cases at longitudinal damage location X_1 is:

$$P_{111-6} (X_1 Y_1 Z_{1-6}) = 0,05786 + 0,01074 + 0,00216 + 0,00216 + 0,00216 + 0,00216 = 0,07725$$

Next, we move to damage extent Y_2 . The damage box $X_1 Y_2 Z_1$ once again falls within the WB1 compartment. Likewise, transverse penetrations Z_2 through Z_6 fall within this compartment. We compute the probability for these cases and find that $P_{121-6} (X_1 Y_2 Z_{1-6}) = 0,01925$.

Similarly, the damage boxes defined by $X_1 Y_3 Z_{1-6}$ lie within the WB1 compartment and have a combined probability $P_{131-6} (X_1 Y_3 Z_{1-6}) = 0,00350$.

We now move to the next longitudinal location, X_2 . With longitudinal extent Y_1 , the damage stays within the WB1 compartment. The combined probability is $P_{211-6} (X_2 Y_1 Z_{1-6}) = 0,07725$.

The forward bound of the damage box $X_2 Y_2 Z_1$ extends forward of the transverse bulkhead located 20,0 m from the transom, damaging compartments both fore and aft of this bulkhead. Transverse penetration Z_1 extends to a point just outboard of the longitudinal bulkhead. Therefore, this combination damages both the WB1 and WB2S compartments. The probability is $P_{221} (X_2 Y_2 Z_1) = 0,01442$.

We find that the damage box $X_2 Y_2 Z_2$ extends inboard of the longitudinal bulkhead, damaging compartments WB1, WB2S and CO1. A cargo oil tank has been damaged and oil outflow will occur. Similarly, damage penetrations Z_3 through Z_6 result in breaching of the three compartments. The combined probability for these five incidents is:

$$P_{222-6} (X_2 Y_2 Z_{2-6}) = 0,00268 + 0,00054 + 0,00054 + 0,00054 + 0,00054 = 0,00483$$

By stepping through the barge for all 180 incidents and combining unique damage compartment groupings, we obtain the compartment grouping and probability values shown in Table A2. (Probability Values for Side Damage) Each compartment group represents a unique set of compartments. The associated probability is the probability that each particular group of compartments will be damaged in a collision which breaches the hull. For instance, the probability of damaging the WB1 compartment is 0,17725. This means there is approximately a 17,7% likelihood that only this compartment will be damaged. Likewise, the probability of concurrently damaging the WB1 and WB2S compartments is 0,03408 or about 3,4%. Note that the cumulative probability of occurrence for all groups equals 1,0.

2.3.2 Bottom damage evaluation

For bottom damage, the probability of a given damage longitudinal location, longitudinal extent, vertical penetration, transverse location and transverse extent is analogously to the side damage evaluation the product of the probabilities of these five damage characteristics.

The following increments are assumed for the bottom damage evaluation:

$$\begin{aligned} \text{Longitudinal location at 10 steps:} &= L/10 = 0,10L \text{ per step} \\ \text{Longitudinal extent at 8 steps:} &= 0,8L/8 = 0,10L \text{ per step} \\ \text{Vertical penetration at 6 steps:} &= 0,3D/6 = 0,05D \text{ per step.} \end{aligned}$$

To further simplify the evaluation, all damage is assumed to extend transversely without limit. Therefore, the probability of transverse extent and transverse location are taken as 1,0 for each damage case.

Compartments groupings are developed using the same process as previously described for side damage.

Analogously, a total of ten longitudinal locations, eight longitudinal extents and six vertical penetrations need to be evaluated. The damage incidents to be taken into account for groundings sum up to a total of $(10)(8)(6) = 480$ separate incidents.

Figure A3 (Bottom Damage Definition) shows the steps for longitudinal location, longitudinal extent and vertical penetration in relation to the barge. Table A3 (Increments for Step-wise Bottom Damage Evaluation) gives the range for each step, the mean or average value over the step, and the probability of occurrence of that particular step.

Again, putting the aftmost compartment WB1 together in terms of damage increments, the following probabilities have to be summed up:

$$\begin{aligned} P_{111-6} &= X_1 Y_1 Z_{1-6} = (0,0240)(0,38333)(1,0) = 0,00920 \\ P_{121-6} &= X_1 Y_2 Z_{1-6} = (0,0240)(0,2500)(1,0) = 0,00600 \\ P_{131-6} &= X_1 Y_3 Z_{1-6} = (0,0240)(0,11677)(1,0) = 0,00280 \\ P_{211-6} &= X_2 Y_1 Z_{1-6} = (0,0320)(0,38333)(1,0) = 0,01227. \end{aligned}$$

Therefore the likelihood of damaging the WB1 compartment sums up to:

$$P_{WB1} = P_{11} + P_{12} + P_{13} + P_{21} = 0,03027.$$

By addressing each of the 480 incidents to the relevant compartment (or groups of compartments) the likelihood of a damage to these resulting from a grounding is obtained. This is shown in Table A4 (Probability Values for Bottom Damage).

2.4 Step 4: Computation of the equilibrium condition for each damage case

This example describes the concept analysis only. Damage stability analyses to determine the equilibrium conditions are only required for the final shipyard design, in accordance with paragraph 5.1.5.10 of the Guidelines.

2.5 Step 5: Computation of the oil outflow for each damage case

In this step the oil outflow associated with each of the compartment groupings is calculated for side and bottom damage as outlined below.

2.5.1 Side damage evaluation

For side damage, 100% of the oil in a damaged cargo oil tank is assumed to outflow into the sea. If we review the eleven compartment groupings for side damage, we find that oil tank damage occurs in three combinations: CO1 only, CO2 only, and concurrent damage to CO1 and CO2. The oil outflow for these tanks is as follows:

CO1 (98% full volume)	=	9 430 m ³
CO2 (98% full volume)	=	28 291 m ³
CO1 + CO2 (98% full volume)	=	37 721 m ³

2.5.2 Bottom damage evaluation

For bottom damage, a pressure balance calculation must be carried out. The vessel is assumed to remain stranded on a shelf at its original intact draft. For the concept analysis, zero trim and zero heel are assumed. An inert gas overpressure of 0,05 bar gauge is assumed in accordance with paragraph 5.1.5.4 of the Guidelines. The double bottom spaces located below the cargo oil tanks "capture" some portion of the oil outflow. In accordance with paragraph 5.1.5.7 of the Guidelines, the flooded volume of such spaces should be assumed to contain 50% oil and 50% seawater by volume at equilibrium. When calculating the oil volume captured in these spaces, no assumptions are made on how the oil and seawater is distributed in these spaces.

The calculations are generally carried out for three tidal conditions: 0,0 meters tide, with a 2,0 meter tidal drop, and with a 6,0 meter tidal drop. In accordance with paragraph 5.1.3 of the Guidelines, the tidal drop need not be taken greater than 50% of the ship's maximum draft. For this example, the appropriate tidal conditions are therefore 0,0 meters, 2,0 meters and 4,5 meters.

The actual oil volume lost from a cargo tank is calculated for each of the three tidal conditions assuming hydrostatic balance as follows:

$$z_c \cdot \rho_c \cdot g + 100 \cdot \Delta_p = z_s \cdot \rho_s \cdot g$$

where:

z_c	=	height of remaining oil in the damaged tank (m)
ρ_c	=	cargo oil density (0,9 t/m ³)
g	=	gravitational acceleration (9,81 m/s ²)
Δ_p	=	set pressure of cargo tank pressure/vacuum valves (0,05 bar g)
z_s	=	external sea water head above innerbottom [m]
z_s	=	T - 2 = 7,00 m
ρ_s	=	sea water density (1,025 t/m ³)

See also Figure A4.

From the above equation one obtains for the height of remaining oil z_c for the zero-tide condition:

$$z_c = 7,40 \text{ m.}$$

Thus, the height of lost oil $h_1 = 0,98 \cdot h_c - z_c$ is:

$$h_1 = 17,64 - 7,40 = 10,24 \text{ m.}$$

The volume of lost oil V_1 of cargo tank CO1 is:

$$V_1 = 10,24 \cdot 36 \cdot 15 \cdot 0,99 = 5\,474 \text{ m}^3.$$

In this case the total volume V_{wo} of oil and water in the waterballast tanks is:

$$V_{wo} = 2 [20 \cdot 2 + z_{wo} \cdot 2] 60 \cdot 0,95 = 6\,202 \text{ m}^3$$

where:

$$z_{wo} = 0,5 (z_c + z_s) = 7,20 \text{ m.}$$

If one assumes that 50% of V_{wo} is occupied by captured oil, one obtains for the total oil outflow $V_{outflow}$ of cargo tank CO1:

$$V_{outflow} = V_1 - 0,5 \cdot V_{wo} = 2\,373 \text{ m}^3.$$

The oil outflow of cargo tank CO2 is:

$$V_{outflow} = 10,24 \cdot 36 \cdot 45 \cdot 0,99 - 0,5 \cdot 6\,202 = 13\,322 \text{ m}^3$$

and the total oil outflow of cargo tanks CO1 and CO2 is:

$$V_{outflow} = 10,24 \cdot 36 \cdot 60 \cdot 0,99 - 0,5 \cdot 6\,202 = 18\,796 \text{ m}^3.$$

Step-wise application of the damage extents and assumed increments results in fourteen compartment groupings for bottom damage. Oil tank and double bottom damage occurs in three combinations. The oil outflows for these tanks at 0,0 meter, 2,0 m and 4,5 m tide are summarized in the table below:

Tank combination	Oil outflow [m ³] at		
	0,0 m tide	2,0 m tide	4,5 m tide
WB2S + WB2P + CO1	2 373	3 832	5 658
WB2S + WB2P + CO2	13 322	17 210	22 081
WB2S + WB2P + CO1 + CO2	18 796	23 898	30 292

2.6 Step 6: Computation of the oil outflow parameters

In this step the oil outflow parameters are computed in accordance with paragraph 4.3 of the Guidelines. To facilitate calculation of these parameters, place the damage groupings in a table in ascending order as a function of oil outflow. A running sum of probabilities is computed, beginning at the minimum outflow damage case and proceeding to the maximum outflow damage case. Tables A5 and A6 (Cumulative Probability and Oil Outflow Values) contains the outflow values for the side damage and bottom damage for the three-tide conditions.

Probability of zero outflow P_O : This parameter equals the cumulative probability for all damage cases for which there is no oil outflow. From Table A5, we see that the probability of zero outflow for the side damage condition is 0,83798, and the probability of zero outflow for the bottom damage (0,0 meter tide) condition is 0,84313.

Mean outflow parameter O_M : This is the weighted average of all cases, and is obtained by summing the products of each damage case probability and the computed outflow for that damage case.

Extreme outflow parameter O_E : This represents the weighted average of the damage cases falling within the cumulative probability range between 0,9 and 1,0. It equals the sum of the products of each damage case probability with a cumulative probability between 0,90 and 1,0 and its corresponding oil outflow, with the result multiplied by 10.

For this example, the computed outflow values are as shown in Tables A5 and A6. In accordance with paragraph 5.1.3 of the Guidelines, the bottom damage outflow parameters for the 0,0, 2,0 and 4,5 meter tides are combined in a ratio of 0,4 : 0,5 : 0,1 respectively. In accordance with paragraph 5.1.2, the collision (side damage) and stranding (bottom damage) parameters are then combined in a ratio of 0,4 : 0,6 respectively. Table A7 (Summary of Oil Outflow Parameters) the oil outflow parameters P_O , O_M and O_E for the example tank barge are listed.

Table A1
Increments for Step-wise
Side Damage Evaluation

Longitudinal Location (step = 0,1L)

	range of increments			probability
	minimum	maximum	midpoint	
X1	0,0L	0,1L	0,05L	0,1000
X2	0,1L	0,2L	0,15L	0,1000
X3	0,2L	0,3L	0,25L	0,1000
X4	0,3L	0,4L	0,35L	0,1000
X5	0,4L	0,5L	0,45L	0,1000
X6	0,5L	0,6L	0,55L	0,1000
X7	0,6L	0,7L	0,65L	0,1000
X8	0,7L	0,8L	0,75L	0,1000
X9	0,8L	0,9L	0,85L	0,1000
X10	0,9L	1,0L	0,95L	0,1000
				1,0000

Longitudinal Extent (step = 0,1L)

	range of extents			probability
	minimum	maximum	average	
Y1	0,0L	0,1L	0,05L	0,7725
Y2	0,1L	0,2L	0,15L	0,1925
Y3	0,2L	0,3L	0,25L	0,0350
				1,0000

Transverse Penetration (step = 0,05B)

	range of penetration			probability
	minimum	maximum	average	
Z1	0,0B	0,05B	0,025B	0,7490
Z2	0,05B	0,10B	0,075B	0,1390
Z3	0,10B	0,15B	0,125B	0,0280
Z4	0,15B	0,20B	0,175B	0,0280
Z5	0,20B	0,25B	0,225B	0,0280
Z6	0,25B	0,30B	0,275B	0,0280
				1,0000

Table A2
Probability Values for Side Damage

Unique Compartment Groupings	Damage Extents and Probabilities	Group Probability
1 WB1	X1Y1Z1-6X1Y2Z1-6X1Y3Z1-6X2Y1Z1-6 0,07725 0,01925 0,00350 0,07725	0,17725
2 WB1 + WB2S	X2Y2Z1 X2Y3Z1 X3Y3Z1 X3Y2Z1 0,01442 0,00262 0,00262 0,01442	0,03408
3 WB1 + WB2S + CO1	X2Y2Z2-6X2Y3Z2-6X3Y2Z2-6 0,00483 0,00088 0,00483	0,01054
4 WB2S	X3Y1Z1 X4Y1Z1 X4Y2Z1 X4Y3Z1 X5Y1Z1 X5Y2Z1 X5Y3Z1 0,05786 0,05786 0,01442 0,00262 0,05786 0,01442 0,00262 X6Y1Z1 X6Y2Z1 X6Y3Z1 X7Y1Z1 X7Y2Z1 X7Y3Z1 X8Y1Z1 0,05786 0,01442 0,00262 0,05786 0,01442 0,00262 0,05786	0,41532
5 WB2S + CO1	X3Y1Z2-6 0,01939	0,01939
6 WB2S + CO1 + CO2	X4Y1Z2-6X4Y2Z2-6X4Y3Z2-6X5Y3Z2-6 0,01939 0,00483 0,00088 0,00088	0,02598
7 WB1 + WB2S + CO1 + CO2	X3Y3Z2-6 0,00088	0,00088
8 WB2S + CO2	X5Y1Z2-6X5Y2Z2-6X6Y1Z2-6X6Y2Z2-6X6Y3Z2-6X7Y1Z2-6X7Y2Z2-6 0,01939 0,00483 0,01939 0,00483 0,00088 0,01939 0,00483 X7Y3Z2-6X8Y1Z2-6 0,00088 0,01939	0,09381
9 WB2S + WB3	X8Y2Z1 X8Y3Z1 X9Y2Z1 X9Y3Z1 0,01442 0,00262 0,01442 0,00262	0,03408
10 WB2S + CO2 + WB3	X8Y2Z2-6X8Y3Z2-6X9Y2Z2-6X9Y3Z2-6 0,00483 0,00088 0,00483 0,00088	0,01142
11 WB3	X9Y1Z1-6X10Y1Z1-X10Y2Z1-X10Y3Z1-6 0,07725 0,07725 0,01925 0,00350	0,17725
		1,00000

Table A3
Increments for Step-wise
Bottom Damage Definition

Longitudinal Location (step = 0,1L)

	range of increments			probability
	minimum	maximum	midpoint	
X1	0,0L	0,1L	0,05L	0,0240
X2	0,1L	0,2L	0,15L	0,0320
X3	0,2L	0,3L	0,25L	0,0400
X4	0,3L	0,4L	0,35L	0,0480
X5	0,4L	0,5L	0,45L	0,0560
X6	0,5L	0,6L	0,55L	0,0800
X7	0,6L	0,7L	0,65L	0,1200
X8	0,7L	0,8L	0,75L	0,1600
X9	0,8L	0,9L	0,85L	0,2000
X10	0,9L	1,0L	0,95L	0,2400
				1,0000

Longitudinal Extent (step = 0,1L)

	range of extents			probability
	minimum	maximum	average	
Y1	0,0L	0,1L	0,05L	0,3833
Y2	0,1L	0,2L	0,15L	0,2500
Y3	0,2L	0,3L	0,25L	0,1167
Y4	0,3L	0,4L	0,35L	0,0500
Y5	0,4L	0,5L	0,45L	0,0500
Y6	0,5L	0,6L	0,55L	0,0500
Y7	0,6L	0,7L	0,65L	0,0500
Y8	0,7L	0,8L	0,75L	0,0500
				1,0000

Vertical Penetration (step = 0,05D)

	range of penetration			probability
	minimum	maximum	average	
Z1	0,0D	0,05D	0,025D	0,5575
Z2	0,05D	0,10D	0,075D	0,2225
Z3	0,10D	0,15D	0,125D	0,0550
Z4	0,15D	0,20D	0,175D	0,0550
Z5	0,20D	0,25D	0,225D	0,0550
Z6	0,25D	0,30D	0,275D	0,0550
				1,0000

Table A4
Probability Values for Bottom Damage

Unique Compartment Groupings	Damage Extents and Probabilities	Group Probability
1 WB1	X1-2Y1Z1-6 X1Y2Z1-6 X1Y3Z1-6 0,02147 0,006 0,0028	0,03027
2 WB1 + WB2S + WB2P	X2-3Y2Z1-2 X2-3Y3Z1-2 X1-4Y4Z1-2 X1-4Y5Z1-2 X1-5Y6Z1-2 X1-5Y7Z1-2 X1-4Y8Z1-2 0,01404 0,00655 0,00562 0,00562 0,0078 0,0078 0,00562	0,05305
3 WB2S + WB2P + WB3	X8-9Y2Z1-2 X8-9Y3Z1-2 X7-10Y4Z1-1 X7-10Y5Z1-1 X6-10Y6Z1-1 X6-10Y7Z1-2 X7-10Y8Z1-2 0,0702 0,03276 0,02808 0,02808 0,0312 0,0312 0,02808	0,24960
4 WB1 + WB2S + WB2P + WB3	X5-6Y8Z1-2 0,00590	0,00530
5 WB2S + WB2P	X3-8Y1Z1-2 X4-7Y2Z1-2 X4-7Y3Z1-2 X5-6Y4Z1-2 X5-6Y5Z1-2 0,1507 0,05928 0,02766 0,0053 0,0053	0,24824
6 WB3	X9-10Y1Z1-1 X10Y2Z1-6 X10Y3Z1-6 0,18867 0,06 0,028	0,25667
7 WB1 + WB2S + WB2P + CO1	X2-3Y2Z3-6 X2Y3Z3-6 X1-2Y4Z3-6 X1Y5Z3-6 X1Y6Z3-6 0,00396 0,00082 0,00062 0,00026 0,00026	0,00592
8 WB2S + WB2P + CO1	X3Y1Z3-6 0,00337	0,00337
9 WB2S + WB2P + CO2	X5-8Y1Z3-6 X5-7Y2Z3-6 X6-7Y3Z3-6 X6Y4Z3-6 0,03508 0,01408 0,00513 0,00088	0,05517
10 WB2S + WB2P + WB3 + CO2	X8-9Y2Z3-6 X8-9Y3Z3-6 X7-10Y4Z3-6 X7-10Y5Z3-6 X7-10Y6Z3-6 X8-10Y7Z3-6 X8-10Y8Z3-6 0,0198 0,00924 0,00792 0,00792 0,00792 0,0066 0,0066	0,06600
11 WB1 + WB2S + WB2P + CO1 + CO2	X3Y3Z3-6 X3-4Y4Z3-6 X2-4Y5Z3-6 X2-5Y6Z3-6 X1-5Y7Z3-6 X1-4Y8Z3-6 0,00098 0,00098 0,00132 0,00194 0,0022 0,00158	0,00903
12 WB2S + WB2P + WB3 + CO1 + CO2	X6Y6Z3-6 X6-7Y7Z3-6 X7Y8Z3-6 0,00088 0,0022 0,00132	0,00440
13 WB1 + WB2S + WB2P + WB3 + CO1 + CO2	X5-6Y8Z3-6 0,0015	0,00150
14 WB2S + WB2P + CO1 + CO2	X4Y1Z3-6 X4Y2Z3-6 X4-5Y3Z3-6 X5Y4Z3-6 X5-6Y5Z3-6 0,00405 0,00264 0,00267 0,00062 0,0015	0,01148
		1,00000

Table A5
Cumulative Probability and Oil Outflow Value

Side Damage	Oil Outflow		Probability	Cumulative Probability	sum of PI	Mean Oil Outflow		Probability	Extreme Outflow	
	OI	PI				PI * OI	PIe		PIe * OIe * 10	
Compartment Groupings	m3					m3				m3
WB1	0,00	0,17725	0,17725	0,17725		0,00				
WB1+WB2S	0,00	0,03408	0,03408	0,21133		0,00				
WB2S	0,00	0,41532	0,41532	0,62665		0,00				
WB2S+WB3	0,00	0,03408	0,03408	0,66073		0,00				
WB3	0,00	0,17725	0,17725	0,83798		0,00				
WB1+WB2S+CO1	9430,00	0,01054	0,01054	0,84852		99,39				
WB2S+CO1	9430,00	0,01939	0,01939	0,86791		182,85				
WB2S+CO2	28291,00	0,09381	0,09381	0,96172		2653,98		0,06172		17461,2052
WB2S+CO2+WB3	28291,00	0,01142	0,01142	0,97314		323,08		0,01142		3230,8322
WB1+WB2S+CO1+CO2	37721,00	0,00088	0,00088	0,97402		33,19		0,00088		331,9448
WB2S+CO1+CO2	37721,00	0,02598	0,02598	1,00000		979,99		0,02598		9799,9158
						4272,49		0,10000		30823,8980

Bottom Damage (0,0 meter tide)

Bottom Damage (0,0 meter tide)	Oil Outflow		Probability	Cumulative Probability	sum of PI	Mean Oil Outflow		Probability	Extreme Outflow	
	OI	PI				PI * OI	PIe		PIe * OIe * 10	
Compartment Groupings	m3					m3				m3
WB1	0,00	0,03027	0,03027	0,03027		0,00				
WB1 +WB2P+WB2S	0,00	0,05304	0,05304	0,08331		0,00				
WB1+WB2P+WB2S+WB3	0,00	0,00530	0,00530	0,08861		0,00				
WB2P+WB2S	0,00	0,24825	0,24825	0,33686		0,00				
WB2P+WB2S+WB3	0,00	0,24960	0,24960	0,58646		0,00				
WB3	0,00	0,25667	0,25667	0,84313		0,00				
WB1 + WB2P + WB2S + CO1	2373,00	0,00592	0,00592	0,84905		14,05				
WB2P+WB2S+CO1	2373,00	0,00337	0,00337	0,85242		8,00				
WB2P+WB2S+CO2	13322,00	0,05518	0,05518	0,90760		735,11		0,00760		1012,4720
WB2P+WB2S+WB3 + CO2	13322,00	0,06600	0,06600	0,97360		879,25		0,06600		8792,5200
WB1+WB2P+WB2S+CO1+CO2	18796,00	0,00903	0,00903	0,98263		169,73		0,00903		1697,2788
WB3+WB2P+WB2S+CO1+CO2	18796,00	0,00150	0,00150	0,98413		28,19		0,00150		281,9400
WB1+WB2P+WB2S+WB3+CO1+CO2	18796,00	0,00440	0,00440	0,98853		82,70		0,00440		827,0240
WB2P+WB2S+CO1+CO2	18796,00	0,01147	0,01147	1,00000		215,59		0,01147		2155,9012
						2132,62		0,10000		14767,1360

Table A6
Cumulative Probability and Oil Outflow Value

Bottom Damage (2,0 meter tide)		Oil Outflow	Probability	Cumulative Probability	Mean Oil Outflow	Probability	Extreme Outflow
Compartment Groupings	Oi	PI	sum of PI	PI * Oi	Pie	Pie * Oie * 10	
WB1	m3	0,03027	0,03027	m3		m3	
WB1 +WB2P+WB2S	0,00	0,05304	0,08331	0,00			
WB1+WB2P+WB2S+WB3C	0,00	0,00530	0,08861	0,00			
WB2P+WB2S	0,00	0,24825	0,33686	0,00			
WB2P+WB2S+WB3	0,00	0,24960	0,58646	0,00			
WB3	0,00	0,25667	0,84313	0,00			
WB1 + WB2P + WB2S + CO1	3832,00	0,00592	0,84905	22,69			
WB2P+WB2S+CO1	3832,00	0,00337	0,85242	12,91			
WB2P+WB2S+CO2	17210,00	0,05518	0,90760	949,65	0,00760	1307,9600	
WB2P+WB2S+WB3 + CO2	17210,00	0,06600	0,97360	1135,86	0,06600	11358,6000	
WB1+WB2P+WB2S+CO1+CO2	23898,00	0,00903	0,98263	215,80	0,00903	2157,9894	
WB3+WB2P+WB2S+CO1+CO2	23898,00	0,00150	0,98413	35,85	0,00150	358,4700	
WB1+WB2P+WB2S+WB3+CO1+CO2	23898,00	0,00440	0,98853	105,15	0,00440	1051,5120	
WB2P+WB2S+CO1+CO2	23898,00	0,01147	1,00000	274,11	0,01147	2741,1006	
				2752,01	0,10000	18975,6320	

Bottom Damage (4,5 meter tide)		Oil Outflow	Probability	Cumulative Probability	Mean Oil Outflow	Probability	Extreme Outflow
Compartment Groupings	Oi	PI	sum of PI	PI * Oi	Pie	Pie * Oie * 10	
WB1	m3	0,03027	0,03027	m3		m3	
WB1 +WB2P+WB2S	0,00	0,05304	0,08331	0,00			
WB1+WB2P+WB2S+WB3C	0,00	0,00530	0,08861	0,00			
WB2P+WB2S	0,00	0,24825	0,33686	0,00			
WB2P+WB2S+WB3	0,00	0,24960	0,58646	0,00			
WB3	0,00	0,25667	0,84313	0,00			
WB1 + WB2P + WB2S + CO1	5658,00	0,00592	0,84905	33,50			
WB2P+WB2S+CO1	5658,00	0,00337	0,85242	19,07	0,00760	1678,1560	
WB2P+WB2S+CO2	22081,00	0,05518	0,90760	1218,43	0,06600	14573,4600	
WB2P+WB2S+WB3 + CO2	22081,00	0,06600	0,97360	1457,35	0,00903	2735,3676	
WB1+WB2P+WB2S+CO1+CO2	30292,00	0,00903	0,98263	273,54	0,00150	454,3800	
WB3+WB2P+WB2S+CO1+CO2	30292,00	0,00150	0,98413	45,44	0,00440	454,3800	
WB1+WB2P+WB2S+WB3+CO1+CO2	30292,00	0,00440	0,98853	133,28	0,01147	1332,8480	
WB2P+WB2S+CO1+CO2	30292,00	0,01147	1,00000	347,45	0,01147	3474,4924	
				3528,05	0,10000	24248,7040	

Table A7
Summary of Oil Outflow Parameters

Bottom Damage	(40%)	(50%)	(10%)	
	0,0 m tide	2,0 m tide	4,5 m tide	Combined
Probability of Zero Outflow P0	0,8431	0,8431	0,8431	0,8431
Mean Outflow m3	2133	2752	3528	2582
Extreme Outflow m3	14767	18976	24249	17820

Combined Side and Bottom Damage	(40%)	(60%)	
	Side	Bottom	
	Damage	Damage	Combined
Probability of Zero Outflow P0	0,8380	0,8431	0,8411
Mean Outflow m3	4272	2582	3258
Extreme Outflow m3	30824	17820	23021
Mean Outflow Parameter OM			0,0864
Extreme Outflow Parameter OE			0,6103

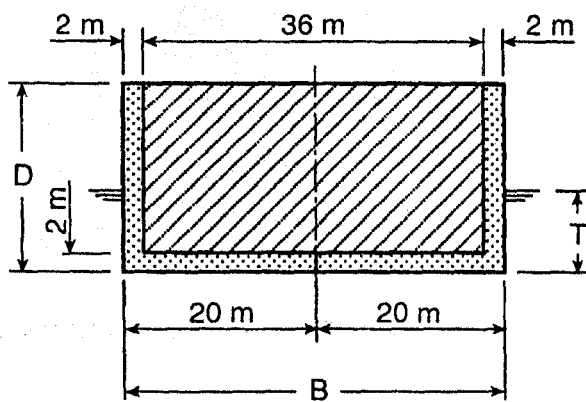
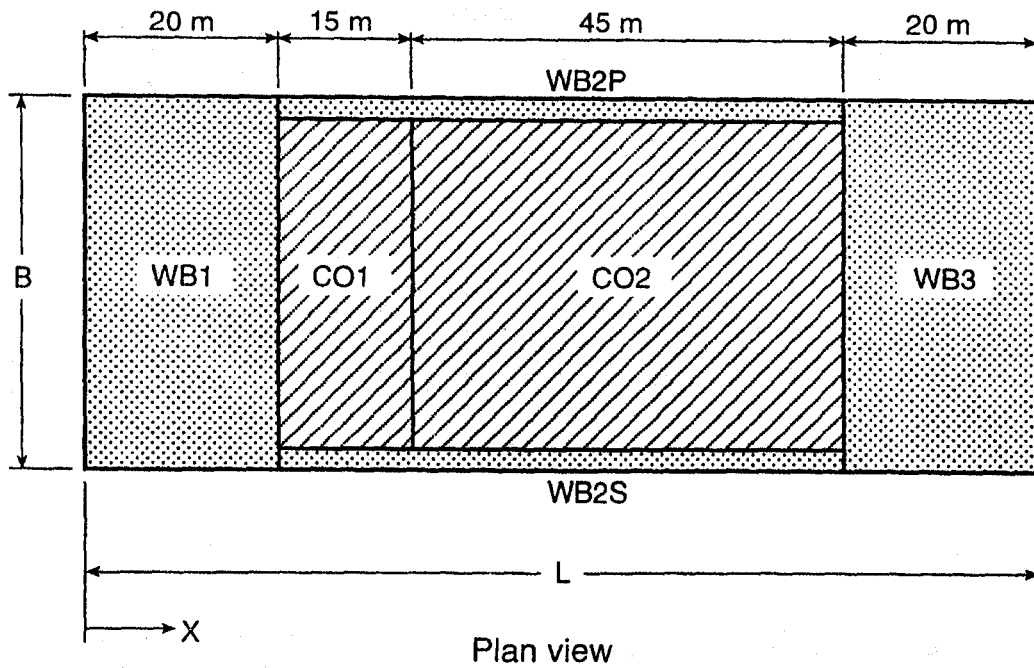

Midship section

Barge Particulars

- L = _____ 100 m
- B = _____ 40 m
- D = _____ 20 m
- T = _____ 9 m
- displacement = _____ 36900 t
- light barge weight = _____ 2951 t
- CO1, CO2 = _____ cargo oil tanks
- WB1, WB2, WB3 = water ballast tanks

Fig. A1: Barge Arrangement

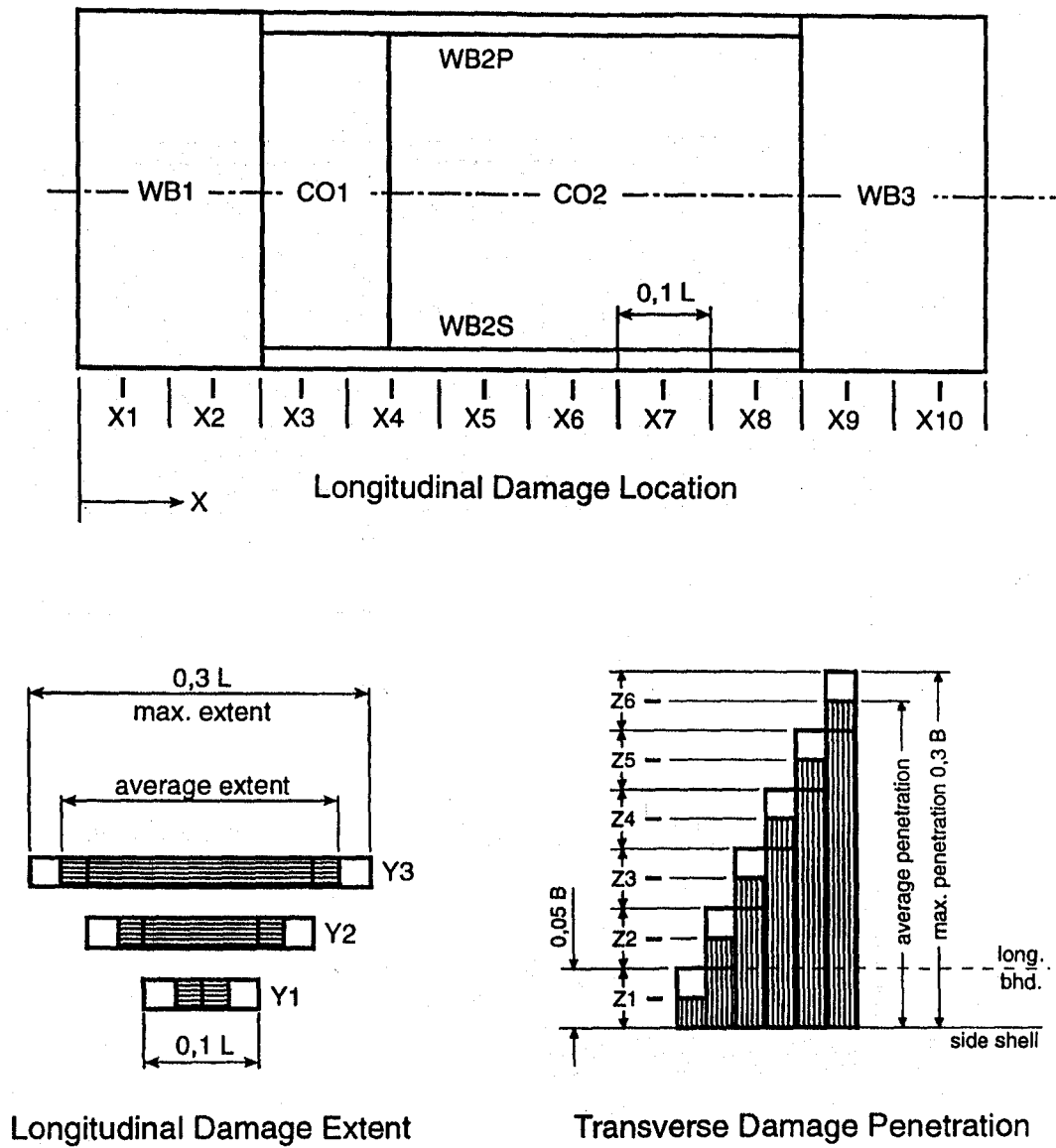

Fig. A2: Side Damage Definition

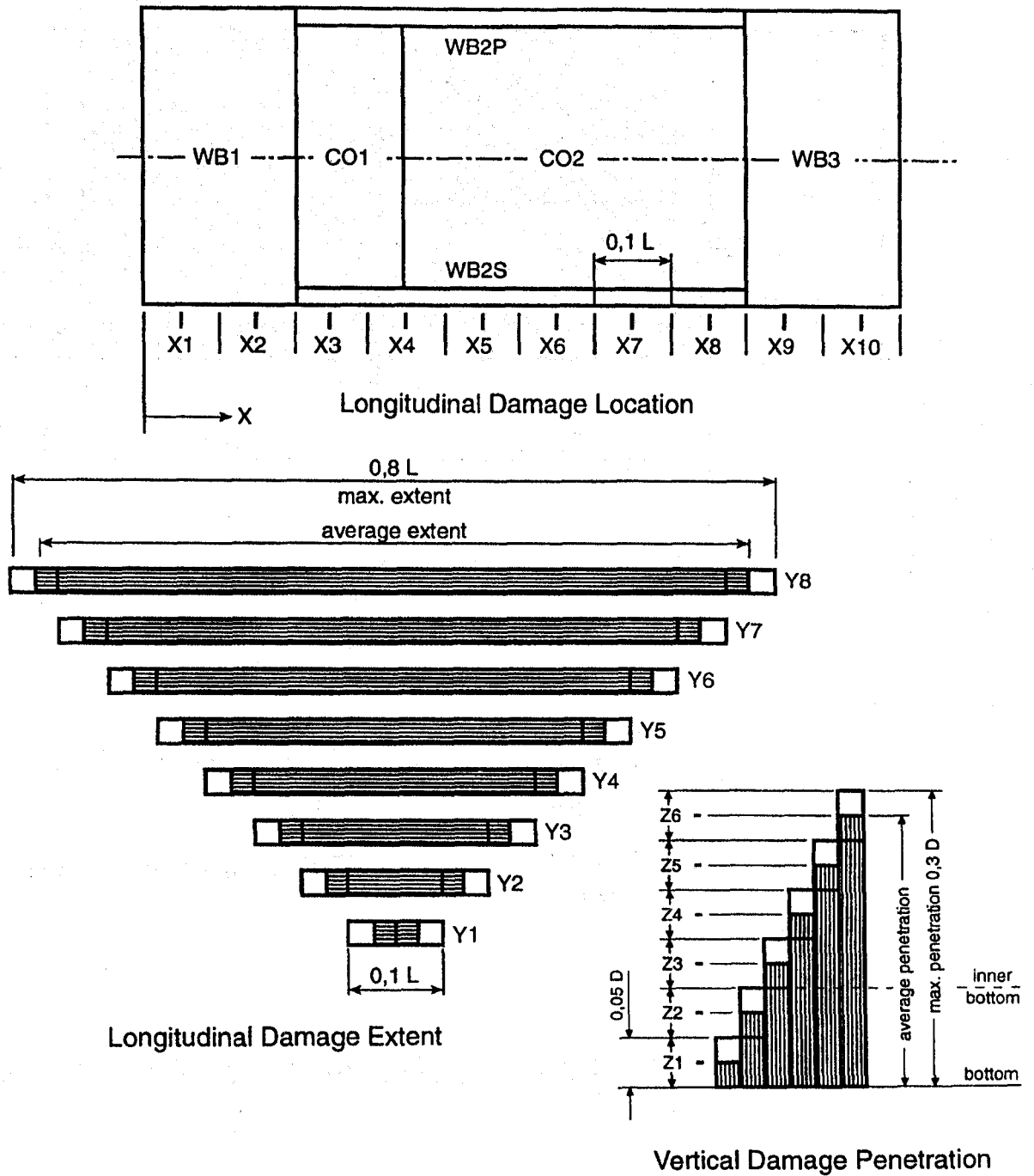
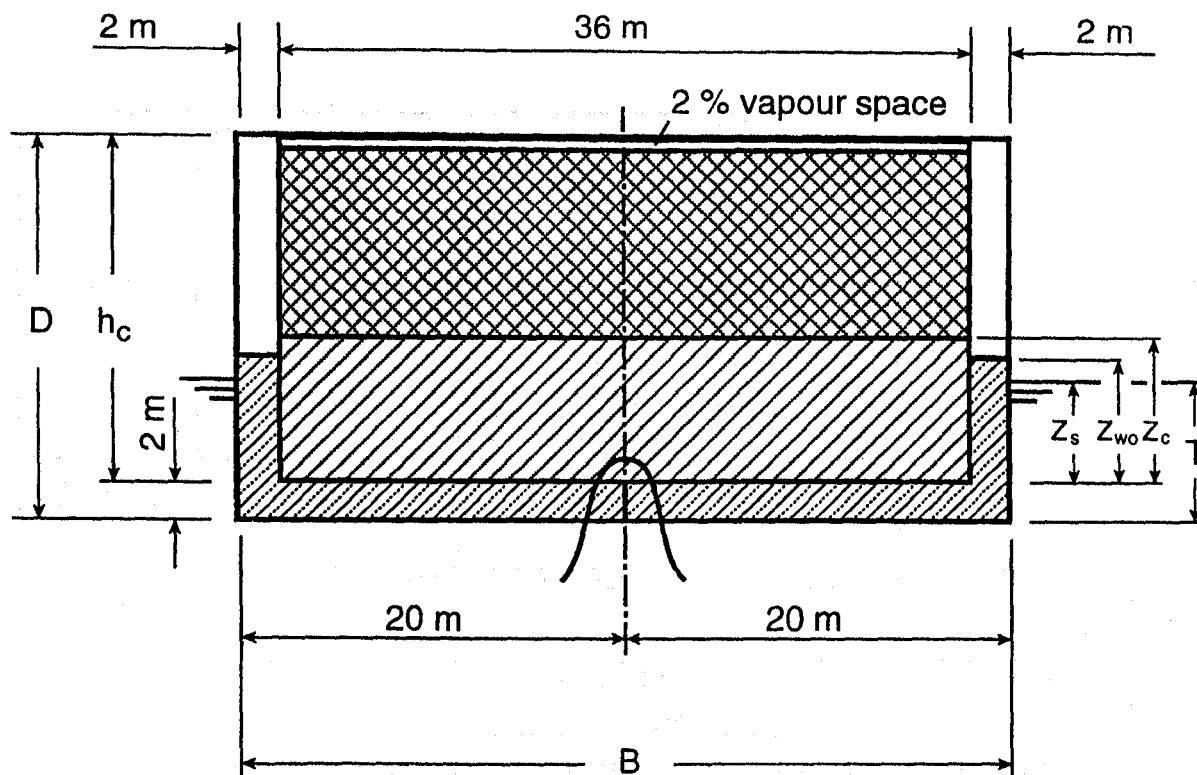

Fig. A3: Bottom Damage Definition



$L_{C01} = 15,0 \text{ m}$
 $L_{C02} = 45,0 \text{ m}$
 $L_{WB2} = 60,0 \text{ m}$
 $h_c = 18,0 \text{ m}$



 50 % oil and 50 % water
 oil
 oil volume lost from cargo tanks

Fig. A4: Oil Outflow Scheme for Bottom Damage
