

ANNEX 6

**RESOLUTION MSC.61(67)
(adopted on 5 December 1996)****ADOPTION OF THE INTERNATIONAL CODE FOR APPLICATION
OF FIRE TEST PROCEDURES**

THE MARITIME SAFETY COMMITTEE,

RECALLING Article 28(b) of the Convention on the International Maritime Organization concerning the functions of the Committee,

RECOGNIZING the need to provide a mandatory application of fire test procedures required by chapter II-2 of the International Convention for the Safety of Life at Sea (SOLAS), 1974, as amended,

NOTING resolution MSC.57(67) by which it adopted, *inter alia*, amendments to chapter II-2 of the SOLAS Convention to make the provisions of the International Code for Application of Fire Test Procedures (FTP Code) mandatory under that Convention on or after 1 July 1998,

HAVING CONSIDERED, at its sixty-seventh session, the text of the proposed FTP Code,

1. ADOPTS the International Code for Application of Fire Test Procedures (FTP Code), the text of which is set out in the Annex to the present resolution;
2. NOTES that, under the amendments to chapter II-2 of the SOLAS Convention, amendments to the FTP Code should be adopted, brought into force and shall take effect in accordance with the provisions of article VIII of that Convention concerning the amendment procedure applicable to the Annex to the Convention other than chapter I;
3. REQUESTS the Secretary-General to transmit certified copies of the present resolution and the text of the FTP Code contained in the Annex to all Contracting Governments to the Convention;
4. FURTHER REQUESTS the Secretary-General to transmit copies of this resolution and the Annex to all Members of the Organization which are not Contracting Governments to the Convention.

ANNEX

INTERNATIONAL CODE FOR APPLICATION OF FIRE TEST PROCEDURES

Contents

- 1 Scope
 - 2 Application
 - 3 Definitions
 - 4 Testing
 - 4.1 Fire test procedures
 - 4.2 Testing laboratories
 - 4.3 Test reports
 - 5 Approval
 - 5.1 General
 - 5.2 Type approval
 - 5.3 Case-by-case approval
 - 6 Products which may be installed without testing and/or approval
 - 7 Use of equivalents and modern technology
 - 8 Period of grace for other test procedures
 - 9 List of references
- Annex 1 Fire test procedures

Preamble

- Part 1 Non-combustibility test
- Part 2 Smoke and toxicity test
- Part 3 Test for "A", "B" and "F" class divisions
 - Appendix 1 - Thermal radiation test supplement to fire resistance tests for windows in "A", "B" and "F" class divisions
 - Appendix 2 - Continuous "B" class divisions
- Part 4 Test for fire door control systems
 - Appendix - Fire test procedure for fire door control systems
- Part 5 Test for surface flammability
 - Appendix - Interpretation of results
- Part 6 Test for primary deck coverings
- Part 7 Test for vertically supported textiles and films
- Part 8 Test for upholstered furniture
- Part 9 Test for bedding components

Annex 2 Products which may be installed without testing and/or approval

Annex 3 Use of other fire test procedures

INTERNATIONAL CODE FOR APPLICATION OF FIRE TEST PROCEDURES

1 SCOPE

1.1 This Code is intended for use by the Administration and the competent authority of the flag State when approving products for installation in ships flying the flag of the flag State in accordance with the fire safety requirements of the International Convention for the Safety of Life at Sea, 1974, as amended.

1.2 This Code shall be used by the testing laboratories when testing and evaluating products under this Code.

2 APPLICATION

2.1 This Code is applicable for the products which are required to be tested, evaluated and approved in accordance with the Fire Test Procedures Code as referenced in the Convention.

2.2 Where reference to the Code is indicated in the Convention by the terminology "... in accordance with the Fire Test Procedures Code" the subject product shall be tested in accordance with the applicable fire test procedure or procedures as referred to in paragraph 4.1.

2.3 Where reference is only made to a product's fire performance in the Convention using such terminology as "... and their exposed surfaces shall have low flame spread characteristics", the subject product shall be tested in accordance with the applicable fire test procedure or procedures as referred to in paragraph 4.1.

3 DEFINITIONS

3.1 "Fire Test Procedures Code" means the International Code for Application of Fire Test Procedures as defined in chapter II-2 of the Convention, as amended.

3.2 "Test expiry date" means the last date on which the given test procedure may be used to test and subsequently approve any product under the Convention.

3.3 "Approval expiry date" means the last date on which the subsequent approval is valid as proof of meeting the fire safety requirements of the Convention.

3.4 "Administration" means the Government of the State whose flag the ship is entitled to fly.

3.5 "Competent authority" means an organization authorized by the Administration to perform functions required by this Code.

3.6 "Laboratory recognized by the Administration" means a testing laboratory which is acceptable to the Administration concerned. Other testing laboratories may be recognized on a case-by-case basis for specific approvals as agreed upon by the Administration concerned.

3.7 "Convention" means the International Convention for the Safety of Life at Sea, 1974, as amended.

3.8 "Standard fire test" means a test in which specimens are exposed in a test furnace to temperatures corresponding approximately to the standard time-temperature curve.

3.9 "The standard time-temperature curve" means the time-temperature curve defined by the formula:

$$T = 345 \log_{10}(8t + 1) + 20$$

where:

T is the average furnace temperature (°C)
t is the time (minutes).

4 TESTING

4.1 Fire test procedures

4.1.1 Annex 1 of this Code presents the required test procedures which shall be used in testing products as a basis for approval (including renewal of approval), except as provided in section 8.

4.1.2 The test procedures identify the test methods and the acceptance and classification criteria.

4.2 Testing laboratories

4.2.1 The tests shall be carried out in testing laboratories recognized by the Administrations concerned.*

4.2.2 When recognizing a laboratory, the Administration shall consider the following criteria:

- .1 that the laboratory is engaged, as a regular part of its business, in performing inspections and tests that are the same as, or similar to, the tests as described in the applicable part;
- .2 that the laboratory has access to the apparatus, facilities, personnel, and calibrated instruments necessary to perform these tests and inspections; and
- .3 that the laboratory is not owned or controlled by a manufacturer, vendor or supplier of the product being tested.

4.2.3 The testing laboratory shall use a quality control system audited by the competent authority.

4.3 Test reports

4.3.1 The test procedures state the required contents of the test reports.

4.3.2 In general, a test report is the property of the sponsor of the test.

*Refer to the list of testing laboratories recognized by the Administrations which is issued and updated in series of FP circulars.

5 APPROVAL

5.1 General

5.1.1 The Administration shall approve products in accordance with their established approval procedures by using the type approval procedure (see paragraph 5.2) or the case-by-case approval (see paragraph 5.3).

5.1.2 The Administration may authorize competent authorities to issue approvals on their behalf.

5.1.3 An applicant who seeks approval shall have the legal right to use the test reports on which the application is based (see paragraph 4.3.2).

5.1.4 The Administration may require that the approved products are provided with special approval markings.

5.1.5 The approval shall be valid when the product is installed on board a ship. If a product is approved when manufactured, but the approval expires before the product is installed on the ship, the product may be installed as approved material, provided that the criteria have not changed since the expiry date of the approval certificate.

5.1.6 The application for approval shall be sought from the Administration or competent authority. The application shall contain at least the following:

- .1 the name and address of the applicant and of the manufacturer;
- .2 the name or trade name of the product;
- .3 the specific qualities for which approval is sought;
- .4 drawings or descriptions of the assembly and materials of the product as well as instructions, where applicable, for its installation and use; and
- .5 a report on the fire test(s).

5.1.7 Any significant alteration to a product shall make the relevant approval to cease to be valid. To obtain a new approval, the product shall be retested.

5.2 Type approval

5.2.1 The type approval certificates shall be issued and renewed on basis of the test reports of the applicable fire tests (see section 4).

5.2.2 The Administration shall require that the manufacturers have a quality control system audited by a competent authority to ensure continuous compliance with the type approval conditions. Alternatively, the Administration may use final product verification procedures where the compliance with the type approval certificate is verified by a competent authority before the product is installed on board ships.

5.2.3 The type approval certificates shall be valid no more than 5 years from the date of issue.

5.2.4 Type approval certificates shall include at least the following:

- .1 identification (name or trade name and description) of the product;
- .2 classification and any restrictions in the use of the product;
- .3 name and address of the manufacturer and applicant;
- .4 test method(s) used in test(s);
- .5 identification of the test report(s) and applicable statements (including date of issue, possible file number and the name and address of the testing laboratory);
- .6 date of issue and possible number of the type approval certificate;
- .7 expiration date of the certificate; and
- .8 name of the issuing body (competent authority) and, if applicable, authorization.

5.2.5 In general, the type approved products may be installed for their intended use on board ships flying the flag of the approving Administration.

5.3 Case-by-case approval

5.3.1 The case-by-case approval means approval where a product is approved for installation on board a specific ship without using a type approval certificate.

5.3.2 The Administration may approve products using the applicable test procedures for specific ship applications without issuing a type approval certificate. The case-by-case approval is only valid for the specific ship.

6 PRODUCTS WHICH MAY BE INSTALLED WITHOUT TESTING AND/OR APPROVAL

Annex 2 of this Code specifies the groups of products, which (if any) are considered to comply with the specific fire safety regulations of the Convention and which may be installed without testing and/or approval.

7 USE OF EQUIVALENTS AND MODERN TECHNOLOGY

7.1 To allow modern technology and development of products, the Administration may approve products to be installed on board ships based on tests and verifications not specifically mentioned in this Code but considered by the Administration to be equivalent with the applicable fire safety requirements of the Convention.

7.2 The Administration shall inform the Organization of approvals referenced to in paragraph 7.1 in accordance with regulation I/5 of the Convention and follow the documentation procedures as outlined below:

- .1 in the case of new and unconventional products, a written analysis as to why the existing test method(s) cannot be used to test this specific product;
- .2 a written analysis showing how the proposed alternative test procedure will prove performance as required by the Convention; and
- .3 a written analysis comparing the proposed alternative test procedure to the required procedure in the Code.

8 PERIOD OF GRACE FOR OTHER TEST PROCEDURES

8.1 The newest test procedures adopted by the Organization are considered being the most suitable for demonstrating that the products concerned comply with the applicable fire safety requirements of the Convention.

8.2 Notwithstanding what is said elsewhere in this Code, the Administration may use established test procedures and acceptance criteria, other than those in annex 1 to this Code, when approving products to comply with the fire safety requirements of the Convention to allow a practicable period of grace for the testing laboratories to obtain testing equipment, for the industry to re-test their products and for the Administrations to provide the necessary new certification. For such other test procedures and acceptance criteria the test expiry dates and the approval expiry dates are given in annex 3 to this Code.

9 LIST OF REFERENCES

The following IMO Assembly resolutions and ISO standards are referred to in parts 1 to 9 of annex 1 to the Code:

- .1 resolution A.471(XII) - "Recommendation on test method for determining the resistance to flame of vertically supported textiles and films";
- .2 resolution A.563(14) - "Amendments to the Recommendation on test method for determining the resistance to flame of vertically supported textiles and films (resolution A.471(XII))";
- .3 resolution A.652(16) - "Recommendation on fire test procedures for upholstered furniture";
- .4 resolution A.653(16) - "Recommendation on improved fire test procedures for surface flammability of bulkhead, ceiling and deck finish materials";
- .5 resolution A.687(17) - "Fire test procedures for ignitability of primary deck coverings";
- .6 resolution A.688(17) - "Fire test procedures for ignitability of bedding components";

- .7 resolution A.753(18) - "Guidelines for the application of plastic pipes on ships";
- .8 resolution A.754(18) - "Recommendation on fire resistance tests for "A", "B" and "F" class divisions";
- .9 ISO 1182:1990 - "Fire test - Building materials - Non-combustibility test";
- .10 ISO 1716:1973 - "Building materials - Determination of calorific potential"; and
- .11 ISO 5659:1994 - "Plastics - Smoke generation, Part 2 Determination of optical density by a single chamber test".

ANNEX 1

FIRE TEST PROCEDURES**Preamble**

1 This annex contains the fire test procedures which shall be used for verifying that the products comply with the applicable requirements. For other test procedures provisions in paragraph 8.2 of, and annex 3 to, the Code shall apply.

2 Reference to the test procedures of this annex shall be made (e.g., in the test report and in the type approval certificate) by referring to the applicable part number or numbers as follows:

Example: Where a primary deck covering has been tested in accordance with parts 2 and 6 of annex 1, the reference shall be "IMO FTPC Parts 2 and 6".

3 Some products or their components are required to be tested in accordance with more than one test procedure. For this purpose, references to other parts are given in some parts of this annex. Such references are here for information only, and the applicable guidance shall be sought in the relevant requirements of the Convention.

4 For products which may be installed without testing and/or approval, annex 2 to the Code is referred.

PART 1 - NON-COMBUSTIBILITY TEST

1 Application

1.1 Where a material is required to be non-combustible, it shall be determined in accordance with this part.

1.2 If a material passes the test as specified in section 2, it shall be considered as "non-combustible" even if it consists of a mixture of inorganic and organic substances.

2 Fire test procedure

2.1 The non-combustibility shall be verified in accordance with the test procedure in the standard ISO 1182:1990 except that instead of Annex A "Criteria for evaluation" of this standard all the following criteria shall be satisfied:

- .1 the average furnace thermocouple temperature rise as calculated in 8.1.2 of ISO 1182 does not exceed 30°C;
- .2 the average surface thermocouple temperature rise as calculated in 8.1.2 of ISO 1182 does not exceed 30°C;
- .3 the mean duration of sustained flaming as calculated in 8.2.2 of ISO 1182 does not exceed 10 s; and
- .4 the average mass loss as calculated in 8.3 of ISO 1182 does not exceed 50%.

2.2 The test report shall include the following information:

- .1 name of testing body;
- .2 name of manufacturer of the material;
- .3 date of supply of the materials and of tests;
- .4 name or identification of the material;
- .5 description of the material;
- .6 density of the material;
- .7 description of the specimens;
- .8 test method;
- .9 test results including all observations;
- .10 designation of the material according to the test criteria specified in paragraph 2.1 above.

PART 2 - SMOKE AND TOXICITY TEST

1 Application

Where a material is required not to be capable of producing excessive quantities of smoke and toxic products or not to give rise to toxic hazards at elevated temperatures, the material shall comply with this part.

2 Fire test procedure

2.1 General

Smoke generation tests shall be conducted in accordance with standard ISO 5659:1994, Part 2 and additional test procedures as described in this part of the Code. To carry out the tests in accordance with this standard, modifications of the arrangements and procedures to the ISO standard shall be made, if necessary.

2.2 Test specimen

Preparation of test specimen shall be in accordance with the practice outlined in resolutions A.653(16), A.687(17) and A.753(18). In the case of cables, only specimens of those with maximum insulation thickness need be tested.

2.3 Test conditions

Irradiance to the specimen during the test shall be kept constant. Three specimens shall be tested under each of the following conditions:

- .1 irradiance of 25 kW/m² in the presence of pilot flame;
- .2 irradiance of 25 kW/m² in the absence of pilot flame; and
- .3 irradiance of 50 kW/m² in the absence of pilot flame.

2.4 Duration of tests

The test shall be carried out for at least 10 min. If the minimum light transmittance value has not been reached during the 10-minute exposure, the test shall be continued for a further 10-minute period.

2.5 Test results

2.5.1 Specific optical density of smoke (D_s) as defined below shall be recorded during the test period at least every 5 s:

$$D_s = (V/(A*L)) * \log_{10}(I_0/I)$$

where:

- V = total volume of the chamber (m³)
- A = exposed area of the specimen (m²)
- L = optical length (m) of smoke measurement
- I₀ = light intensity before the test
- I = light intensity during the test (after absorption by the smoke).

2.5.2 When making toxicity measurements, the sampling of fumes shall be made during the testing of the second or the third specimen at each test condition, from the geometrical centre of the chamber within 3 min of the time when the maximum specific optical density of smoke is reached. The concentration of each toxic gas shall be determined as ppm in the chamber volume.

2.6 Classification criteria

2.6.1 Smoke

An average (D_m) of the maximum of D_s of three tests at each test condition shall be calculated.

- .1 for materials used as surface of bulkheads, linings or ceilings, the D_m shall not exceed 200 in any test condition;
- .2 for materials used as primary deck covering, the D_m shall not exceed 400 in any test condition;
- .3 for materials used as floor covering, the D_m shall not exceed 500 in any test condition; and
- .4 for plastic pipes and electric cables, the D_m shall not exceed 400 in any test condition.

2.6.2 Toxicity

The gas concentration measured at each test condition shall not exceed the following limits:

CO	1450 ppm	HBr	600 ppm
HCl	600 ppm	HCN	140 ppm
HF	600 ppm	SO ₂	120 ppm
NO _x	350 ppm		

2.7 Test report

A test report shall contain the following information:

- .1 type of the material, i.e. surface finish, floor covering, primary deck covering, pipes, etc;
- .2 trade name of the material;
- .3 description of the material;
- .4 construction of the specimen;
- .5 name and address of the manufacturer of the material;
- .6 Dm at each heating and ignition condition;
- .7 concentrations of toxic gases in ppm, if applicable;
- .8 judgement according to paragraph 2.6;
- .9 name and address of the testing laboratory; and
- .10 date of testing

3 Additional requirements

- 3.1 Part 5 of this annex is also applicable to paints, floor coverings, varnishes and other finishes used on exposed interior surfaces.
- 3.2 Part 6 of this annex is also applicable to the primary deck coverings.

PART 3 - TEST FOR "A", "B" AND "F" CLASS DIVISIONS

1 Application

Where products (such as decks, bulkheads, doors, ceilings, linings, windows, fire dampers, pipe penetrations and cable transits) are required to be "A" or "B" or "F" class divisions, they shall comply with this part*.

2 Fire test procedure

2.1 The products shall be tested and evaluated in accordance with the fire test procedure specified in resolution A.754(18). This contains test procedures also for windows, fire dampers and pipe and duct penetrations in its appendices.

2.2 Specimen sizes

2.2.1 For the purpose of this Code, the first sentence of paragraphs 2.1.1, 2.4.1 and 2.7.1 of the Annex to resolution A.754(18) is replaced by the following:

"The minimum overall dimensions of test specimen, including the perimeter details at the top, bottom and vertical edges, are 2,440 mm width and 2,500 mm height, except that the minimum overall dimensions of 2,440 mm in height and 4.65 m² in the exposed surface of the test specimen may be used in testing up to 31 December 1998. The approval expiry date is 31 December 2003 for approvals based on tests with such smaller test specimen."

2.2.2 For the purpose of this Code, the first sentence of paragraphs 2.2.1, 2.5.1 and 2.8.1 of the Annex to resolution A.754(18) is replaced by the following:

"The minimum overall dimensions of test specimen, including the perimeter details at all the edges, are 2,440 mm width and 3,040 mm length, except that the minimum overall dimensions of 2,440 mm in length and 4.65 m² in the exposed surface of the test specimen may be used in testing up to 31 December 1998. The approval expiry date is 31 December 2003 for approvals based on tests with such smaller test specimen."

2.2.3 The specimen sizes shall be given in the test reports

2.3 Where thermal radiation through windows is required to be limited, the window assembly may be tested and evaluated in accordance with appendix 1 of this part.

2.4 Where ceilings or linings are required to be continuous "B" class ceilings or linings they may be tested and evaluated in accordance with appendix 2 of this part.

*Products tested for use in buildings have similar classification markings. However, they do not correspond to the classes in marine use.

3 Additional requirements

3.1 The integrity of class "B" constructions shall be achieved with non-combustible materials. Adhesives used in the construction of the specimen are not required to be non-combustible; however, for the purpose of this Code, they shall have low flame-spread characteristics.

3.2 Materials placed at "B" class panel joints for avoiding vibration or noise transmission shall be of low flame spread characteristics and fire tested with "B" class divisions along which they are used. However, such materials shall be non-combustible if they are necessary to support the non-combustible "B" class structure or to achieve the required integrity.

3.3 Doors and shutters, which are fitted above the bulkhead deck and which are required to meet both fire protection and watertight requirements, shall comply with the fire protection requirements as required in the Convention, for the divisions where they are installed. The watertight doors fitted below the bulkhead deck are not required to be insulated.

4 Other references

4.1 The non-combustibility of materials used in "A" and "B" class divisions shall be verified in accordance with part 1.

4.2 Where combustible veneers are allowed to be provided in "A" and "B" class divisions, the low flame spread characteristics of such veneers, if required, shall be verified in accordance with part 5.

APPENDIX 1

THERMAL RADIATION TEST SUPPLEMENT TO FIRE RESISTANCE TESTS FOR WINDOWS IN "A", "B" AND "F" CLASS DIVISIONS

1 Scope

1.1 This appendix specifies a procedure for measuring heat flux through windows as a basis for characterizing their ability to limit the heat radiation in order to prevent the spread of fire and to enable escape routes to pass near the windows.

1.2 This procedure is an optional requirement and may be requested by some Administrations for windows in specific areas of a ship.

2 Test procedure

2.1 The window should be tested in accordance with resolution A.754(18) using the additional instrumentation as described below.

2.2 The term "window" includes windows, side scuttles and any other glazed opening provided for light transmission or vision purposes in a fire resistant division. The term "fire resistant division" includes bulkheads and doors.

3 Additional instrumentation

3.1 Additional instrumentation consists of a restricted-view total-heat fluxmeter calibrated with the restricted view to indicate incident heat flux. The fluxmeter should be water-cooled and capable of measuring heat flux 0 to 60 kW/m². The fluxmeter should be calibrated at least once a year against a standard device.

3.2 The fluxmeter should be placed perpendicular to the centre of the window being tested, and in a position such that the centre of the fluxmeter's view coincides with the centre of the window* (see the figure). The fluxmeter should be located at a distance greater than 0.5 m from the window, such that the view of the fluxmeter just includes part of the frame. However, the fluxmeter should not be located more than 2.5 m from the window. The dimension of the boundary and window frame seen by the fluxmeter, which remains outside the window should not exceed 10% of the total width seen by the fluxmeter on the surface of the sample. It should be calculated on the basis of restricted view angle of the fluxmeter and its distance to the sample surface.

*A satisfactory method of placing, mounting, and aiming the fluxmeter is as follows: A metal stand constructed of a pipe mounted on a sturdy base serves as an instrument tree to locate the fluxmeter at the required distance from the test specimen. A suitable holder for the fluxmeter is constructed by mounting a gun-sight mount on a lockable ball and socket joint. This joint provides flexibility for aiming the meter. The fluxmeter holder is mounted on the instrument tree at the appropriate height. A laser pointer is placed in the gun-sight mount and the mount is oriented such that the dot is in the centre of the window. The laser pointer is slipped out of the holder and replaced by the fluxmeter.

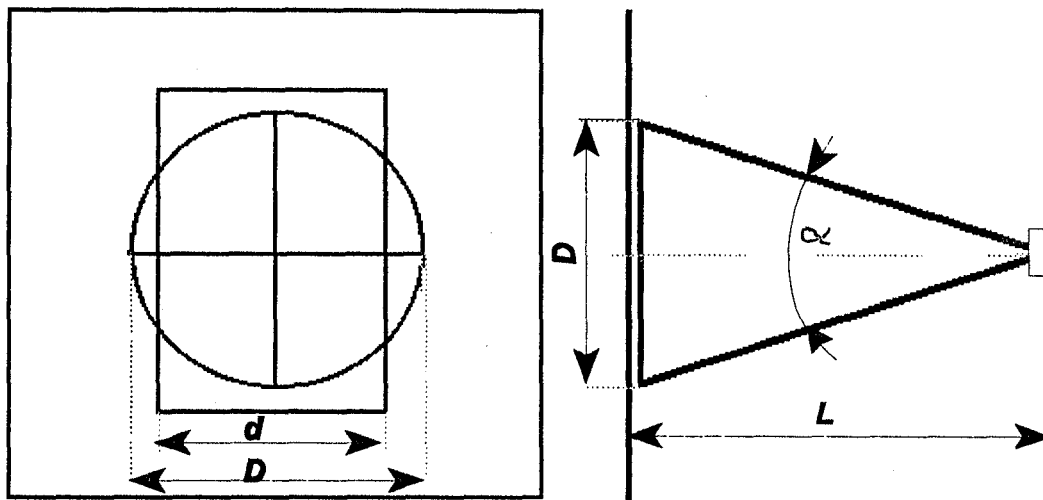

$$\frac{d}{D} \geq 0.9$$

- α — restricted view angle
- L — distance, m
- D — view diameter, m
- $D = 2L \cdot \tan \frac{\alpha}{2}$

3.3 For windows whose greater dimension is less than 1.57 times the smaller dimension, only one fluxmeter is needed.

3.4 For oblong windows whose greater dimension is more than 1.57 times the smaller dimension, additional fluxmeters should be provided. The distance of the fluxmeters from the window should be adjusted such that the fluxmeters' view covers at least 50% of the window. However, the fluxmeters should not be located less than 0.5 m nor more than 2.5 m from the window.

Figure

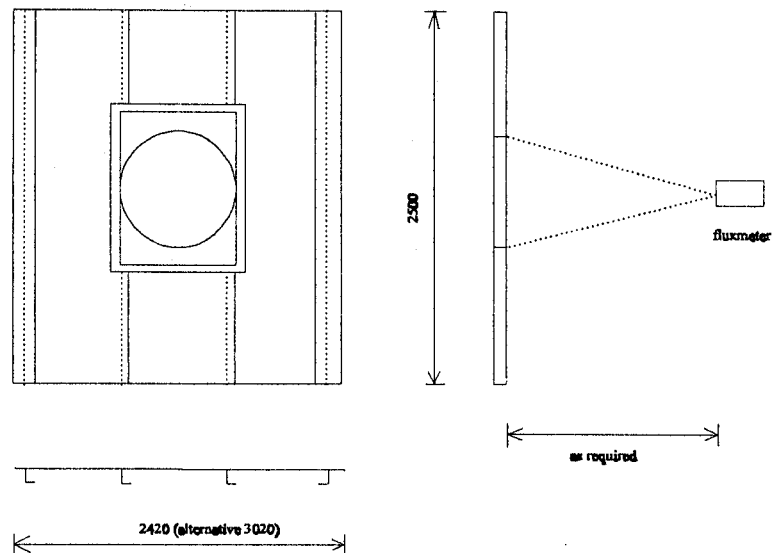

4 Classification criteria

4.1 The peak heat flux (E_w) should be measured for the first 15 min of the test, for the first 30 min of the test, and for the entire duration of the test (i.e. 60 min for class "A" and 30 min for class "B" boundaries).

4.2 The peak heat fluxes (E_w) measured in accordance with paragraph 4.1 should be compared against the reference value (E_c) from the table.

4.3 If (E_w) is less than (E_c), the window is acceptable for installation in a boundary of the corresponding fire resistant classification.

Table 1 - Criteria for heat flux

Fire resistant division classification	Time period from beginning of test to	Heat flux E_c (kW/m²)
A-0	60 minutes	56.5
A-15	15 minutes 60 minutes	2.34 8.0
A-30	30 minutes 60 minutes	2.34 6.4
A-60	60 minutes	2.34
B-0	30 minutes	36.9
B-15	15 minutes 30 minutes	2.34 4.3

APPENDIX 2

CONTINUOUS "B" CLASS DIVISIONS

1 Scope

1.1 This appendix specifies the procedure for testing linings and ceilings for verifying that they are "continuous 'B' class linings" and "continuous 'B' class ceilings" and for evaluating full constructions to be "continuous 'B' class constructions".

1.2 This procedure is an optional requirement and may be requested by some Administrations for continuous "B" class divisions.

2 Test procedure and evaluation

2.1 The linings, ceilings and constructions should be evaluated in accordance with resolution A.754(18) using the arrangements described below.

2.2 The ceilings should be tested in accordance with paragraph 2.8 of the Annex to resolution A.754(18) except that the ceiling should be mounted on the horizontal furnace so that at least 150 mm high "B" class bulkheads are mounted on the furnace and the ceiling is fixed to these partial bulkheads by using the joining method as is intended to be used in practice. Such ceilings and the joining methods should be evaluated as required for ceilings in accordance with resolution A.754(18) and accordingly they should be classified as "continuous 'B' (B-0 or B-15, as applicable) class ceilings".

2.3 A lining which has been evaluated in accordance with resolution A.754(18) to be a "B" (B-0 or B-15, as applicable on basis of the lining test) class lining may be considered forming "continuous 'B' (B-0 or B-15, as applicable) class lining" in conjunction with a "continuous 'B' (B-0 or B-15, as applicable) class ceiling" and with the joining method used in the test (see paragraph 2.2 above) without further testing the lining.

2.4 An enclosed construction installed on an "A" class deck and formed by "continuous 'B' (B-0 or B-15, as applicable) class linings" and "continuous 'B' (B-0 or B-15, as applicable) class ceiling" should be considered forming "continuous 'B' class construction".

PART 4 - TEST FOR FIRE DOOR CONTROL SYSTEMS

1 Application

Where a control system of fire doors is required to be able to operate in case of fire, the system shall comply with this part.

2 Fire test procedure

The fire door control systems shall be tested and evaluated in accordance with the test procedure presented in the appendix to this part.

3 Additional requirements

Part 1 of this annex is also applicable to insulation materials used in connection with a fire door control system.

APPENDIX

FIRE TEST PROCEDURE FOR FIRE DOOR CONTROL SYSTEMS

1 General

- 1.1 Fire door control systems which are intended to be used for fire doors capable of operating in case of fire shall be tested in accordance with the fire test procedure described in this appendix independent of its power supply (pneumatical, hydraulic or electrical).
- 1.2 The fire tests shall be a prototype test and be carried out with the complete control system in a furnace dimensioned according to resolution A.754(18).
- 1.3 The construction to be tested shall be, as far as practicable, representative of that to be used on board ships, including the materials and method of assembly.
- 1.4 The functions of the control system including its closing mechanism shall be tested, i.e. normal functions of and, if required, emergency function, including switchover functions, if this is a basis of the manufacturer's design. The required kind of installation and functions shall be evident from a detailed function description.

2 Nature of prototype control systems

- 2.1 The installation of the prototype control system shall fully comply with the manufacturer's installation manual.
- 2.2 The prototype control system shall include a typical door arrangement connected to the closing mechanism. For the purpose of the test a door model shall be used. In case of sliding doors, the model door shall run in original door tracks with original supporting and guide rollers. The model door shall have the weight of the largest door to be actuated by this control system.
- 2.3 In case of pneumatic or hydraulic systems, the actuator (cylinder) shall have the maximum length allowed by the furnace.

3 Materials for prototype control systems

3.1 Specifications

Prior to the test, drawings and the list of materials of the test arrangement shall be submitted to the laboratory by the applicant.

3.2 Control measurements

- 3.2.1 The testing laboratory shall take reference specimens of all those materials whose characteristics are important to the performance of the prototype control system (excluding steel and equivalent material).

3.2.2 If necessary, non-combustibility tests of insulation material in accordance with part 1 shall be conducted. Adhesives used in the construction of the specimen are not required to be non-combustible, however, they shall have low flame-spread characteristics.

3.2.3 The density of each insulation material shall be determined. The density of mineral wool or any similar compressible material shall be related to the nominal thickness.

3.2.4 The thickness of each insulation material and combination of materials shall be measured by using a suitable gauge or calipers.

4 Conditioning of the prototype control systems

4.1 Conditioning of the prototype control system (except insulation) is not necessary.

4.2 If insulation material is used in the construction, the prototype control system shall not be tested until the insulation has reached an air dry condition. This condition is designed as an equilibrium (constant weight) with an ambient atmosphere of 50% relative humidity at 23°C.

Accelerated conditioning is permissible provided the method does not alter the properties of component materials. High temperature conditioning shall be below temperatures critical for the materials.

5 Mounting of the prototype control systems

5.1 The prototype fire door control system and the insulation, if used for protection of the system or parts of it, shall be mounted at the bulkhead plate as shown in figure 1.

5.2 The structural core shall be mounted at the furnace in accordance with the principles for 'A' class divisions in paragraph 5 of resolution A.754(18).

5.3 The door model shall be arranged within the furnace. The structural core to which the system and the door model are fitted shall have no door opening. However, small openings for the release mechanism of the control systems are allowed.

6 Examination of the prototype control systems

6.1 Conformity

The laboratory shall verify the conformity of the prototype control system with the drawings and method of assembly provided by the applicant (see section 2), and any area of discrepancy shall be resolved prior to commencement of the test.

6.2 Operation of the prototype control system

Immediately prior to the test, the laboratory shall check the operability of the system by opening the door model by a distance of at least 300 mm. The door model shall then be closed.

7 Instrumentation

The furnace and the instrumentation of the furnace shall be in accordance with section 7 of the Annex to resolution A.754(18).

8 Method of test

8.1 Commencement of test

Not more than 5 min before the commencement of the test, the initial temperatures recorded by all thermocouples shall be checked to ensure consistency and the datum values shall be noted. Similar datum values shall be obtained for deformation, and initial condition of the prototype control system shall be noted.

At the time of the test, the initial average internal temperature shall be $20 \pm 10^{\circ}\text{C}$ and shall be within 5°C of the initial ambient temperature.

8.2 Furnace control

The furnace control shall be in accordance with paragraph 8.3 of the Annex to resolution A.754(18)

8.3 Temperatures, duration of testing and actions during test

8.3.1 The average furnace temperature shall be increased and stabilized at $200 \pm 50^{\circ}\text{C}$ within 5 min and kept at the level of $200 \pm 50^{\circ}\text{C}$ up to the end of the first 60 min. Then the average furnace temperature shall be increased according to the standard time-temperature curve beginning with the level of 200°C up to 945°C .

8.3.2 The opening and closing function of the door control mechanism shall be activated every 5 min from the beginning of the test for the duration of 60 min.

8.3.3 The automatic switchover shall isolate the door control system from the power supply at the average furnace temperature of 300°C and shall be able to keep the door closed at least up to 945°C .

8.4 Measurements and observations on the prototype control system

In case of pneumatic or hydraulic systems, the input pressure which shall be identical with the approved system pressure shall be recorded. Due to a high input pressure, necessary safety precautions shall be taken when the test is carried out.

9 Classification criteria

9.1 During the first 60 min of the test, a prototype fire door control system shall not fail.

9.2 During the period from the end of the first 60 min until the end of the test, the door shall remain closed.

10 Test report

The test report shall include all important information relevant to the prototype control system and the fire test, including the following specific items:

- .1 the name of the testing laboratory and the test date;
- .2 the name of the applicant for the test;
- .3 the name of the manufacturer of the prototype control system and of the products and components used in the construction, together with identification marks and trade names;
- .4 the constructional details of the prototype control system, including description and drawings and principal details of components. All the details requested in section 2 shall be given. The description and the drawings which are included in the test report shall, as far as practicable, be based on information derived from a survey of the prototype control system. When full and detailed drawings are not included in the report, then the applicant's drawing(s) of the prototype control system shall be authenticated by the laboratory and at least one copy of the authenticated drawing(s) shall be retained by the laboratory; in this case reference to the applicant's drawing(s) shall be given in the report together with a statement indicating the method of endorsing the drawings;
- .5 all the properties of materials used that have a bearing on the fire performance of the prototype control system together with measurements of thickness and density of the insulation material(s);
- .6 a statement that the test has been conducted in accordance with the requirements of this Appendix and if any deviations have been made to the prescribed procedures (including any special requirements of the Administration), a clear statement of the deviations;
- .7 the name of the representative of the Administration present at the test. When the test is not witnessed by a representative of the Administration, a note to this effect shall be made in the report in the following form:

“The (name of the Administration) ... was notified of the intention to conduct the test detailed in this report and did not consider it necessary to send a representative to witness it.”;
- .8 information concerning the location of the pressure gauges or other devices together with tabulated data obtained during the test;
- .9 observations of significant behaviour of the prototype control system during test and photographs, if any; and
- .10 a statement that the prototype fire door control system has passed the test and complies with the classification criteria.

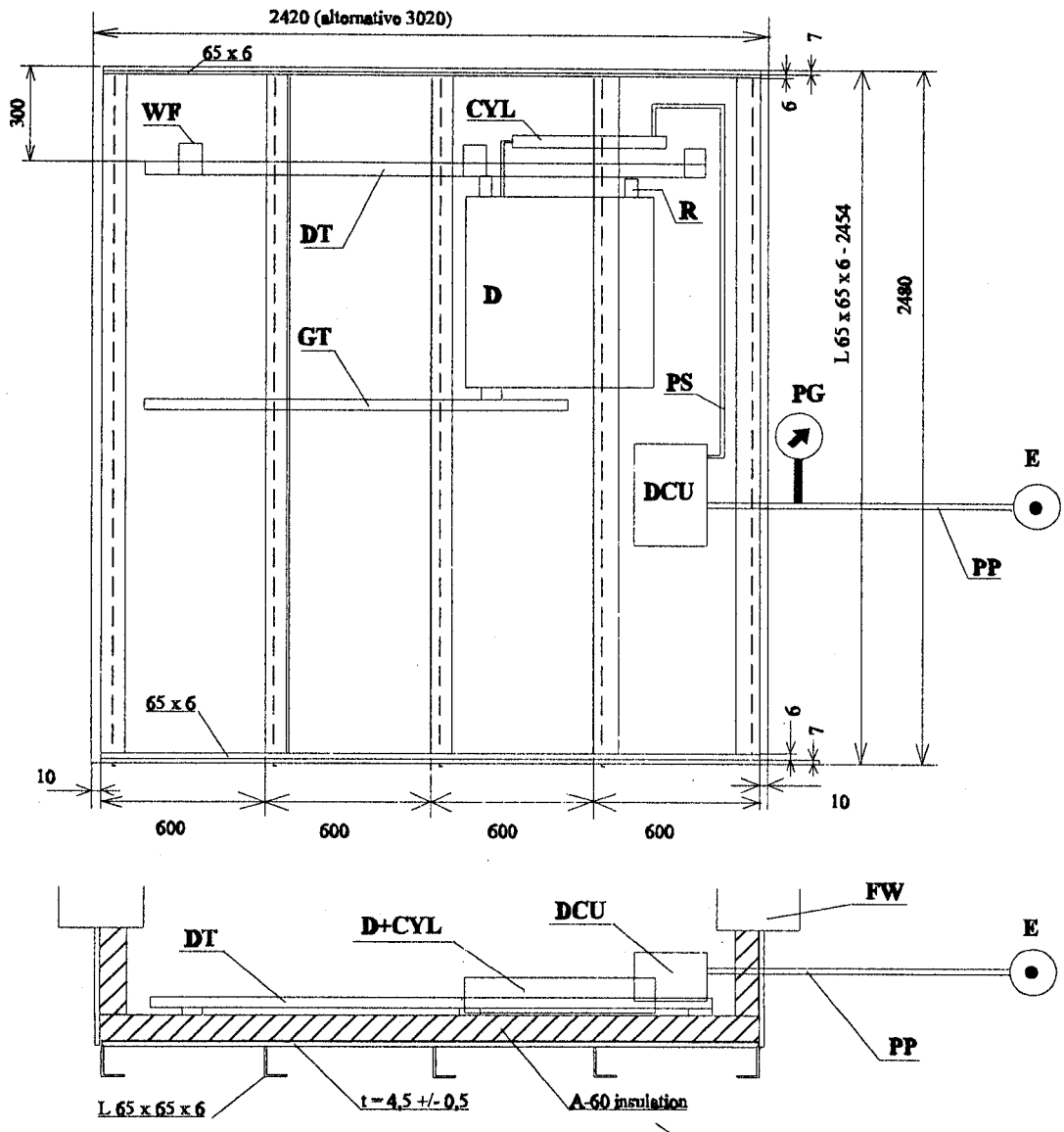

Figure 1 - Structural core for fitting the prototype fire door control system. D = door model, DCU = door control unit, DT = door track, WF = weld fastening, GT = guide track, CYL = door cylinder, R = supporting roller, PS = piping system, PG = pressure gauge, PP = pressure pipe, E = energy, FW = furnace wall.

PART 5 - TEST FOR SURFACE FLAMMABILITY

1 Application

Where a product is required to have a surface with low flame-spread characteristics, the product shall comply with this part.

2 Fire test procedure

2.1 The surface materials shall be tested and evaluated in accordance with the test procedure specified in resolution A.653(16). For the purpose of this part, the total heat release value (Q_t) for floor coverings given in section 10 of the Annex to resolution A.653(16) is replaced by ≤ 2.0 MJ. The test may be terminated after 40 min.

2.2 During fire tests for bulkhead, ceiling and deck finish materials and primary deck coverings (see part 6 of this annex for primary deck coverings), there are those specimens which exhibit various phenomena which cause difficulties in classification of the materials. Appendix to this part provides guidance on the uniform interpretation of such results.

3 Additional requirements

3.1 Surface materials for bulkheads and ceilings and similar exposed surfaces

In case there is a requirement of maximum gross calorific value (e.g. 45 MJ/m²) for a product, the method specified in standard ISO 1716: 1973 is recommended for determining the gross calorific value.

3.2 Floor coverings and primary deck coverings

3.2.1 A primary deck covering is the first layer of a floor construction which is applied directly on top of the deck plating and is inclusive of any primary coat, anti-corrosive compound or adhesive which is necessary to provide protection or adhesion to the deck plating. Other layers in the floor construction above the deck plating are floor coverings.

3.2.2 Where a floor covering is required to be low flame-spread, all layers shall comply with part 5. If the floor covering has a multilayer construction, the Administration may require the tests to be conducted for each layer or for combinations of some layers of the floor coverings. Each layer separately, or a combination of layers (i.e. the test and approval are applicable only to this combination), of the floor covering shall comply with this part. When a primary deck covering is required to be not readily ignitable and is placed below a floor covering, the primary deck covering shall comply with part 6. When the primary deck covering is also the exposed surface, it shall comply with this part. Primer or similar thin film of paint on deck plating need not comply with the above requirements of part 6.

3.3 Combustible ventilation ducts

3.3.1 Where combustible ventilation ducts are required to be of material which has low flame-spread characteristics, the surface flammability test procedure and criteria for lining and ceiling finishes according to resolution A.653(16) shall be applied for such ducts. In case homogeneous materials are used for the ducts, the test shall apply to outside surface of the duct, whilst both sides of the ducts of composite materials shall be tested.

3.4 Insulation materials for cold service systems

Where the exposed surfaces of vapour barriers and adhesives used in conjunction with insulation, as well as insulation of pipe fittings, for cold service systems are required to have low flame-spread characteristics, the surface flammability test procedure and criteria for linings and ceilings according to resolution A.653(16) shall be applied for such exposed surfaces.

3.5 Other references

Part 2 of this annex is also applicable to surface materials.

APPENDIX

INTERPRETATION OF RESULTS Evaluating unusual test specimen behaviour (see paragraph 2.2 of this part)

	Unusual behaviour	Guidance on classification
1	Flashing, no steady flame	Report furthest progress of flame and time, and whether or not flash is on centerline. Classify on basis of the data.
2	Explosive spalling, no flashing or flame	Accept material as passing test.
3	Rapid flash over surface, later steady flame progress	Report result for both flame fronts but classify on basis of worst performance for each of the four test parameters in the two burning regimes.
4	Specimen or veneer melts and drips off, no flame	Report behaviour and extent of advance on specimen.
5	Explosive spalling, and flame on exposed part of specimen	Report explosions and classify on basis of flame progress irrespective of whether above or below centerline.
6	Specimen or veneer melts, burns, and drips off	Reject material regardless of criteria. For floor covering, no more than 10 burning drops are acceptable.
7	Pilot flame extinguished	Report occurrence, reject data and repeat test.
8	Heat release signal after test and re-insertion of dummy specimen remains at a higher or lower level than initial stabilizing level.	Reject data and stabilize the equipment, then repeat test.
9	Very short ignition delay on carpets or non-rigid specimens	Could be caused by pile extension above holder surface, reducing space to pilot flame. Repeat with shims as required by procedure in paragraph 8.1.1 of the Annex to resolution A.653(16).

- | | | |
|----|---|---|
| 10 | Specimen breaks up, and falls out of holder | Report behaviour, but classify on basis of worst performance with and without specimen restraint in paragraph 8.3.2 of the Annex to resolution A.653(16). |
| 11 | Substantial jetting combustible pyrolysis gases from specimen, adhesive or bonding agents | Reject material. |
| 12 | Small flame remaining along the edge of specimen | Report behaviour and terminate the test 3 min after flaming on exposed surface of specimen ceased. |

PART 6 - TEST FOR PRIMARY DECK COVERINGS

1 Application

1.1 Where the primary deck coverings are required to be not readily ignitable, they shall comply with this part.

1.2 For determining which layers on the deck shall be tested as floor coverings and which of them shall be tested as primary deck coverings, see paragraph 3.2 of part 5.

2 Fire test procedure

2.1 The primary deck coverings shall be tested and evaluated in accordance with the fire test procedure specified in resolution A.687(17):

2.2 The test shall be terminated after 40 min.

3 Additional requirements

Part 2 of this annex 1 is also applicable to primary deck coverings.

PART 7 - TEST FOR VERTICALLY SUPPORTED TEXTILES AND FILMS

1 Application

Where draperies, curtains and other supported textile materials are required to have qualities of resistance to the propagation of flame not inferior to those of wool of mass 0.8 kg/m², they shall comply with this part .

2 Fire test procedure

The vertically supported textiles and films shall be tested and evaluated in accordance with the fire test procedure specified in resolution A.471(XII) as amended by resolution A.563(14).

3 Additional requirements

The tests shall be made by using specimens of the final product (e.g. with colour treatment). In cases where only the colours change, a new test is not necessary. However, in cases where the basis product or the treatment procedure change, a new test is required.

PART 8 - TEST FOR UPHOLSTERED FURNITURE

1 Application

Where upholstered furniture are required to have qualities of resistance to the ignition and propagation of flame, the upholstered furniture shall comply with this part.

2 Fire test procedure

The upholstered furniture shall be tested and evaluated in accordance with the fire test procedure specified in resolution A.652(16).

3 Additional requirements

The tests shall be made by using specimens of the final product (e.g. with colour treatment). In cases where only the colours change, a new test is not necessary. However, in cases where the basis product or the treatment procedure change, a new test is required.

PART 9 - TEST FOR BEDDING COMPONENTS

1 Application

Where bedding components are required to have qualities of resistance to the ignition and propagation of flame, the bedding components shall comply with this part.

2 Fire test procedure

The bedding components shall be tested and evaluated in accordance with the fire test procedure specified in resolution A.688(17).

3 Additional requirements

The tests shall be made by using specimens of the final product (e.g. with colour treatment). In cases where only the colours change, a new test is not necessary. However, in cases where the basis product or the treatment procedure change, a new test is required.

ANNEX 2

PRODUCTS WHICH MAY BE INSTALLED WITHOUT TESTING AND/OR APPROVAL

General

In general, the products and product groups listed in this annex are considered to have the fire safety characteristics specified below and they may be installed without testing according to and without approval on basis of the specific fire test procedures in this Code for the specific safety characteristics of the product.

The paragraphs below are numbered with the same part number in which the corresponding testing requirements are specified in annex 1.

1 Non-combustible materials

In general, products made only of glass, concrete, ceramic products, natural stone, masonry units, common metals and metal alloys are considered being non-combustible and they may be installed without testing and approval.

2 Materials not generating excessive quantities of smoke nor toxic products in fire

2.1 In general, non-combustible materials are considered to comply with the requirements of part 2 of annex 1 without further testing.

2.2 In general, surface materials and primary deck coverings with both the total heat release (Q_t) of not more than 0.2 MJ and the peak heat release rate (q_p) of not more than 1.0 kW (both values determined in accordance with part 5 of annex 1 or in accordance with resolution A.653(16)) are considered to comply with the requirements of part 2 of annex 1 without further testing.

3 "A", "B" and "F" class divisions

3.1 The following products may be installed without testing or approval:

Classification	Product description
Class A-0 bulkhead	A steel bulkhead with dimensions not less than the minimum dimensions given below: <ul style="list-style-type: none">- thickness of plating: 4 mm- stiffeners 60 x 60 x 5 mm spaced at 600 mm or structural equivalent

Class A-0 deck

A steel deck with dimensions not less than the minimum dimensions given below:

- thickness of plating: 4 mm
- stiffeners 95 x 65 x 7 mm spaced at 600 mm or structural equivalent.

3.2 Notwithstanding the provisions in 3.1 above, the materials which are used in "A", "B" and "F" class divisions and which are required to have certain other specified characteristics (e.g. non-combustibility, low flame-spread characteristics, etc.) shall comply with the appropriate parts of annex 1 or section 8 and annex 3, of this Code.

4 Fire door control systems
(no entries)

5 Low flame-spread surfaces

5.1 Non-combustible materials are considered to comply with the requirements of part 5 of annex 1. However, due consideration shall be given to the method of application and fixing (e.g. glue).

5.2 Primary deck coverings classified as not readily ignitable in accordance with part 6 of annex 1 are considered to comply with the requirements of part 5 of annex 1 for floor coverings.

6 Primary deck coverings

Non-combustible materials are considered to comply with the requirements of part 6 of annex 1. However, due consideration shall be given to the method of application and fixing.

7 Vertically supported textiles and films
(no entries)

8 Upholstered furniture
(no entries)

9 Bedding components
(no entries)

ANNEX 3

USE OF OTHER FIRE TEST PROCEDURES

Administrations may use test procedures other than those referred to in annex 1 as follows:

- .1 for fire test procedures previously adopted by the Assembly, the expiry dates are given in the table below; and
- .2 for other established test procedures and acceptance criteria applied by an Administration, the test expiry date is 31.12.1998 and the approval expiry date is 31.12.2003.

Products (reference part in annex 1)	Test procedure	Test expiry date	Approval expiry date
Non-combustible materials (part 1)	Resolution A.472(XII)	31.12.1998	31.12.2003
	Resolution A.270(VIII)	1.7.1997	1.7.2002
Materials not generating excessive quantities of smoke nor toxic products (part 2)	-	-	-
A, B and F class divisions (part 3)	Resolution A.517(13)*	31.12.1998	31.12.2003
	Resolution A.163(ES.IV)* as corrected by Resolution A.215(VII)	1.7.1997	1.7.2002
	Resolution A.163(ES.IV)*	1.7.1997	1.7.2002
Fire door control systems (part 4)	-	-	-
Surface materials (part 5)	Resolution A.564(14)	31.12.1998	31.12.2003
	Resolution A.516(13)	31.12.1998	31.12.2003
Primary deck coverings (part 6)	Resolution A.214(VII)	31.12.1998	31.12.2003
Vertically supported textiles (part 7)	Resolution A.471(XII)	31.12.1998	31.12.2003
Upholstered furniture (part 8)	-	-	-
Bedding components (part 9)	-	-	-

*The maximum average temperature rise of 140°C may be used instead of 139°C in the acceptance criteria in resolutions A.163(ES.IV) and A.517(13).
