

RECOMMENDATION ON INTACT STABILITY OF  
FISHING VESSELS

The Assembly,

*Noting* Article 16(i) of the Convention on the Inter-Governmental Maritime Consultative Organization concerning the functions of the Assembly,

*Noting also* Recommendation 7 of the International Conference on Safety of Life at Sea, 1960,

*Recognizing* the need to establish international standards for intact stability of fishing vessels,

*Having considered* the Recommendation adopted by the Maritime Safety Committee at its seventeenth session,

*Adopts* the Recommendation on Intact Stability of Fishing Vessels, the text of which is set out in the Annex to this Resolution,

*Invites* all governments concerned to take steps to give effect to the Recommendation as soon as possible unless they are fully satisfied that their national stability requirements supported by long operating experience ensure adequate stability for particular types and sizes of ships,

*Requests* the Maritime Safety Committee to continue the study of this subject including the formulation of specific requirements on icing for vessels off the east coast of Canada during the winter months, and to develop improved stability criteria,

*Authorizes* the Maritime Safety Committee to amend the Recommendation as necessary in the light of further studies.

## ANNEX

RECOMMENDATION ON INTACT STABILITY  
OF FISHING VESSELS1. *Scope*

1.1. The provisions given hereunder are intended for new decked sea-going fishing vessels.

1.2. Administrations are invited to adopt, for all conditions of loading, the stability criteria given in paragraph 5 unless they are satisfied that operating experience justifies departures therefrom.

2. *General Precautions against Capsizing*

2.1. Compliance with the stability criteria does not ensure immunity against capsizing regardless of the circumstances or absolve the master from his responsibilities. Masters should therefore exercise prudence and good seamanship having regard to the season of the year, weather forecasts and the navigational zone and should take note of the particular advice contained in Appendix VIII.

2.2. Care should be taken to stow the cargo so that compliance with the criteria can be achieved. If necessary the use of ballast may be permitted to achieve compliance with the criteria.

2.3. To minimize the possibility of both longitudinal and lateral shifting of the cargo under the effect of accelerations caused by rolling and pitching, appropriate subdivision of the hold and, if necessary, of the deck should be arranged. The scantlings given in Appendix V are recommended for hold divisions.

2.4. The Recommendation relating to freeing ports in bulwarks are contained in Appendix VI.

2.5. The Recommendations for the height of door sills and hatchway coamings are contained in Appendix VII.

### 3. *Calculation of Stability Curves*

The methods and procedures employed for calculating stability righting arms should be in accordance with Appendix I, and the degree of accuracy obtained should be acceptable to the Administration.

### 4. *Assessment of Compliance with Criteria*

4.1. For the purpose of assessing in general whether the criteria are met, stability curves should be drawn for the main loading conditions intended by the owner in respect of the ship's operations.

4.2. If the owner does not supply sufficiently detailed information regarding such loading conditions, calculations should be made for the standard conditions given in Appendix II.

4.3. In all cases calculations should be based on the assumptions shown in Appendix II.

### 5. *Recommended Criteria*

5.1. The following criteria are recommended for fishing vessels:

- (a) The area under the righting lever curve (GZ curve) should not be less than 0.055 metre-radians up to  $\theta = 30^\circ$  angle of heel and not less than 0.09 metre-radians up to  $\theta = 40^\circ$  or the angle of flooding  $\theta_f^*$  if this angle is less than  $40^\circ$ .

Additionally, the area under the righting lever curve (GZ curve) between the angles of heel of  $30^\circ$  and  $40^\circ$  or between  $30^\circ$  and  $\theta_f$ , if this angle is less than  $40^\circ$ , should not be less than 0.03 metre-radians.

- (b) The righting lever GZ should be at least 0.20 m. at an angle of heel equal to or greater than  $30^\circ$ .
- (c) The maximum righting arm should occur at an angle of heel preferably exceeding  $30^\circ$  but not less than  $25^\circ$ .
- (d) The initial metacentric height  $GM_0$  should not be less than 0.35 m.

---

\*  $\theta_f$  is an angle of heel at which openings in the hull, superstructures or deckhouses which cannot be closed weathertight immerse. In applying this criterion, small openings through which progressive flooding cannot take place need not be considered as open.

5.2. The criteria mentioned in 5.1. fix minimum values, but no maximum values are recommended. It is advisable to avoid excessive values, since these might lead to acceleration forces which could be prejudicial to the ship, its complement, its equipment and to the safe carriage of the cargo.

5.3. Where anti-rolling devices are installed in a ship the Administration should be satisfied that the above criteria can be maintained when the devices are in operation.

5.4. The adoption by individual countries of simplified criteria which apply such basic stability values to their own types and classes of vessels is recognized as a practical and valuable method of economically judging the stability.

5.5. A number of influences such as beam wind on ships with large windage area, icing of topsides (see Appendix III), water trapped on deck, rolling characteristics, following seas, etc. adversely affect stability and the Administration is advised to take these into account so far as is deemed necessary.

## 6. *Inclining Test*

6.1. When construction is finished, each ship should undergo an inclining test, actual displacement and co-ordinates of the centre of gravity being determined for the light ship condition.

6.2. The Administration may allow the inclining test of an individual ship to be dispensed with, provided basic stability data are available from the inclining test of a sister ship.

## 7. *Stability Information*

7.1. The master of any ship to which the present Recommendation applies should receive information which will enable him to assess with ease and certainty the stability of his ship in different service conditions. A duplicate of this information should be communicated to the Administration.

7.2. Stability information should comprise:

- (i) Stability characteristics of typical loading conditions.
- (ii) Information in the form of tables or diagrams which will enable the master to assess the stability of his ship and verify whether it is sufficient in all loading conditions differing from the standard ones. This information should include, in particular, a curve or table giving as a function of the draughts, the required initial metacentric height  $GM_0$  (or any other stability parameter) which ensures that the stability is in compliance with the criteria given in 5.1. above.
- (iii) Information on the proper use of anti-rolling devices if these are installed in the ship.
- (iv) Additionally, information enabling the ship's master to determine the initial metacentric height  $GM_0$  by means of rolling test as described in the Appendix to the Memorandum to Administrations reproduced at Appendix IV, would be desirable.
- (v) Notes on the corrections to be made to the initial metacentric height  $GM_0$  to take account of free surface liquids.

## APPENDIX I

### CALCULATION OF STABILITY CURVES

#### *General*

(1) Hydrostatic and stability curves should normally be prepared on a designed trim basis. However, where the operating trim or the form and arrangement of the ship are such that change in trim has an appreciable effect on righting arms, such change in trim should be taken into account.

(2) The calculations should take into account the volume to the upper surface of the deck sheathing. In the case of wood ships the dimensions should be taken to the outside of the hull planking.

#### *Superstructures, deckhouses, etc. which may be taken into account*

(3) Enclosed superstructures complying with Regulation 3(10)(b) of the 1966 Load Line Convention (except that door sills should comply with Appendix VII) may be taken into account.

(4) The second tier of similarly enclosed superstructures may also be taken into account.

(5) Deckhouses on the freeboard deck may be taken into account, provided that they comply with the conditions for enclosed superstructures laid down in Regulation 3(10)(b) of the 1966 Load Line Convention (except that door sills should comply with Appendix VII).

(6) Where deckhouses comply with the above conditions except that no additional exit is provided to a deck above, such deckhouses should not be taken into account; however, any deck openings inside such deckhouses shall be considered as closed even where no means of closure are provided. Such deckhouses in which, due to smallness of the vessel, an additional exit would be impracticable may be taken into account.

(7) Deckhouses, the doors of which do not comply with the requirements of Regulation 12 of the 1966 Load Line Convention, should not be taken into account; however, any deck openings inside the deckhouse are regarded as closed where their means of closure comply with the requirements of Regulations 15, 17 or 18 of the 1966 Load Line Convention.

(8) Deckhouses on decks above the freeboard deck should not be taken into account, but openings within them may be regarded as closed.

(9) Superstructures and deckhouses not regarded as enclosed may under special circumstances be taken into account in stability calculations up to the angle at which the openings are flooded, provided this does not lead to subsequent serious flooding of the vessel. (At this angle, the statical stability curve should show one or more steps, and in subsequent computations the flooded space should be considered non-existent.)

(10) In cases where the ship would sink due to flooding through any openings, the stability curve should be cut short at the corresponding angle of flooding and the ship should be considered to have entirely lost her stability.

(11) Small openings such as those for passing wires or chains, tackle and anchors, and also holes of scuppers, discharge and sanitary pipes should not be considered as open if they submerge at an angle of inclination more than  $30^{\circ}$ . If they submerge at an angle of  $30^{\circ}$  or less, these openings should be assumed open if the Administration considers this to be a source of significant flooding.

(12) Trunks may be taken into account. Hatchways may also be taken into account having regard to the effectiveness of their closures.

*Effect of liquid in tanks*

(13) For all conditions, the initial metacentric height and the stability curves should be corrected for the effect of free surfaces of liquids in tanks in accordance with the following assumptions:

- (i) Tanks which are taken into consideration when determining the effect of liquids on the stability at all angles of inclination should include single tanks or combinations of tanks for each kind of liquid (including those for water ballast) which according to the service conditions can simultaneously have free surfaces.
- (ii) For the purpose of determining this free surface correction, the tanks assumed slack should be those which develop the greatest free surface moment,  $M_{f.s.}$  at a  $30^{\circ}$  inclination, when in the 50 per cent full condition.
- (iii) the value of  $M_{f.s.}$  for each tank may be derived from the formula:

$$M_{f.s.} = vb\gamma k\sqrt{\delta}$$

where:

- $M_{f.s.}$  = the free surface moment at any angle of inclination in metre-tons,
- $v$  = the tank total capacity in  $m^3$ ,
- $b$  = the tank maximum breadth in m,
- $\gamma$  = the specific weight in liquid in the tank in  $t/m^3$ ,
- $\delta$  =  $\frac{v}{blh}$  = the tank block coefficient,
- $h$  = the tank maximum height in m,
- $l$  = the tank maximum length in m,
- $k$  = dimensionless coefficient to be determined from the following table according to the ratio  $b/h$ . The intermediate values are determined by interpolation (linear or graphic).

TABLE OF VALUES FOR COEFFICIENT "K" FOR CALCULATING  
FREE SURFACE CORRECTIONS

$\theta$ b/h	$k = \frac{\sin \theta}{12} (1 + \frac{\tan^2 \theta}{2}) \times b/h$ where $\cot \theta \geq b/h$										$k = \frac{\cos \theta}{8} (1 + \frac{\tan \theta}{b/h}) - \frac{\cos \theta}{12(b/h)} 2 (1 + \frac{\cot^2 \theta}{2})$ where $\cot \theta \leq b/h$															
	5°	10°	15°	20°	30°	40°	45°	50°	60°	70°	75°	80°	90°	5°	10°	15°	20°	30°	40°	45°	50°	60°	70°	75°	80°	90°
20	0.11	0.12	0.12	0.12	0.11	0.10	0.09	0.09	0.09	0.09	0.09	0.09	0.09	0.09	0.09	0.09	0.09	0.09	0.09	0.09	0.09	0.09	0.09	0.09	0.09	0.09
10	0.07	0.11	0.12	0.12	0.11	0.10	0.10	0.10	0.10	0.10	0.10	0.10	0.10	0.10	0.10	0.10	0.10	0.10	0.10	0.10	0.10	0.10	0.10	0.10	0.10	0.10
5	0.04	0.07	0.10	0.11	0.11	0.11	0.11	0.11	0.11	0.11	0.11	0.11	0.11	0.11	0.11	0.11	0.11	0.11	0.11	0.11	0.11	0.11	0.11	0.11	0.11	0.11
3	0.02	0.04	0.07	0.09	0.11	0.11	0.11	0.11	0.11	0.11	0.11	0.11	0.11	0.11	0.11	0.11	0.11	0.11	0.11	0.11	0.11	0.11	0.11	0.11	0.11	0.11
2	0.01	0.03	0.04	0.06	0.09	0.11	0.11	0.11	0.11	0.11	0.11	0.11	0.11	0.11	0.11	0.11	0.11	0.11	0.11	0.11	0.11	0.11	0.11	0.11	0.11	0.11
1.5	0.01	0.02	0.03	0.05	0.07	0.10	0.11	0.11	0.11	0.11	0.11	0.11	0.11	0.11	0.11	0.11	0.11	0.11	0.11	0.11	0.11	0.11	0.11	0.11	0.11	0.11
1	0.01	0.01	0.02	0.03	0.05	0.07	0.09	0.10	0.11	0.11	0.11	0.11	0.11	0.11	0.11	0.11	0.11	0.11	0.11	0.11	0.11	0.11	0.11	0.11	0.11	0.11
0.75	0.01	0.01	0.02	0.02	0.04	0.05	0.07	0.08	0.10	0.11	0.11	0.11	0.11	0.11	0.11	0.11	0.11	0.11	0.11	0.11	0.11	0.11	0.11	0.11	0.11	0.11
0.5	0.00	0.01	0.01	0.02	0.02	0.04	0.04	0.05	0.07	0.09	0.10	0.11	0.11	0.11	0.11	0.11	0.11	0.11	0.11	0.11	0.11	0.11	0.11	0.11	0.11	0.11
0.3	0.00	0.00	0.01	0.01	0.01	0.02	0.03	0.04	0.05	0.06	0.07	0.08	0.09	0.10	0.11	0.11	0.11	0.11	0.11	0.11	0.11	0.11	0.11	0.11	0.11	0.11
0.2	0.00	0.00	0.00	0.01	0.01	0.01	0.02	0.03	0.04	0.05	0.06	0.07	0.08	0.09	0.10	0.11	0.11	0.11	0.11	0.11	0.11	0.11	0.11	0.11	0.11	0.11
0.1	0.00	0.00	0.00	0.00	0.00	0.01	0.01	0.02	0.03	0.04	0.05	0.06	0.07	0.08	0.09	0.10	0.11	0.11	0.11	0.11	0.11	0.11	0.11	0.11	0.11	0.11

- (iv) Small tanks, which satisfy the following condition using the value of  $k$  corresponding to the angle of inclination of  $30^{\circ}$ , need not be included in computation:

$$v_b \gamma k \sqrt{\delta} < 0.01 \Delta_{\min}$$

where:

$\Delta_{\min}$  = minimum ship displacement in tons

- (v) The usual remainder of liquids in the empty tanks is not taken into account in computations.

## APPENDIX II

### STANDARD CONDITIONS OF LOADING TO BE EXAMINED

#### 1. *Loading Conditions*

The standard loading conditions referred to in 4.2. of the Recommendations are as follows:

- (i) departure condition for the fishing grounds with full fuel, stores, ice, fishing gear, etc.;
- (ii) departure from the fishing grounds with full catch;
- (iii) arrival at home port with 10 per cent stores, fuel, etc., remaining and full catch;
- (iv) arrival in home port with 10 per cent stores, fuel, etc. remaining and with 20 per cent of full catch.

#### 2. *Assumptions for Calculating Loading Conditions*

- (1) Allowance is to be made for the weight of the wet fishing nets and tackle, etc. on deck.
- (2) An allowance for icing, where this is anticipated to occur should be made in accordance with Appendix III.
- (3) In all cases the cargo should be assumed to be homogeneous unless this is inconsistent with practice.
- (4) In conditions 1(ii) and (iii) above deck cargo should be included if such a practice is anticipated.
- (5) Water ballast should normally only be included if carried in tanks which are specially provided for this purpose.

### APPENDIX III

#### RECOMMENDATIONS ON MINIMUM REQUIREMENTS ON ICING OF FISHING VESSELS

Administrations which have not yet established requirements on icing are invited by the Maritime Safety Committee to make use of the following minimum requirements:

- (a) The vessel's stability should be calculated in the worst conditions of loading, taking into consideration the risk of icing if the vessel operates in winter seasonal zones.
- (b) Weight of ice per square metre of all exposed weather decks and gangways should be assumed not less than  $30 \text{ kg/m}^2$  - if the vessel operates to the north of latitude  $66^{\circ}30' \text{ N}$ , or to the south of latitude  $60^{\circ}00' \text{ S}$ , as well as in winter in the Barents, Bering and Okhotsk Seas and Tatar Strait. Weight of ice per square metre of projected lateral area of the portion of the vessel above water plane should be assumed not less than  $15 \text{ kg/m}^2$ .
- (c) In other areas of the winter seasonal zone the assumed standards of icing in winter should be one-half of those given in item (b).
- (d) The height of the centre of gravity of ice accumulated should be calculated according to the position of the corresponding parts of the decks and gangways, and other continuous surfaces on which ice can accumulate. The projected lateral area of discontinuous surfaces of rail, spars (except masts) and rigging of the vessels having no sails and the projected lateral area of other small objects should be computed by increasing the total projected lateral area of continuous surfaces by 5 per cent and the static moments of this area by 10 per cent.
- (e) For vessels operating off the east coast of Canada during the winter months it is recommended that each Administration should give consideration to more severe requirements.

### APPENDIX IV

#### MEMORANDUM TO ADMINISTRATIONS ON AN APPROXIMATE DETERMINATION OF SHIP'S STABILITY BY MEANS OF THE ROLLING PERIOD TESTS (for ships up to 70 m. in length)

1. Recognizing the desirability of supplying to Masters of small ships instructions for a simplified determination of initial stability, attention was given to the rolling period test. Studies on this matter have now been completed with the result that the rolling period test may be recommended as a useful means of approximately determining the initial stability of small ships when it is not practicable to give approved loading conditions or other stability information, or as a supplement to such information.



2. Investigations comprising the evaluation of a number of inclining and rolling tests according to various formulae showed that the following formula gave the best results and it has the advantage of being the simplest:

$$GM_o = \left(\frac{fB}{T_r}\right)^2$$

where:

- f = factor for the rolling period  
(different for feet and metric system),
- B = breadth of the ship in feet or metric units,
- T<sub>r</sub> = time for a full rolling period in seconds  
(i.e. for one oscillation "to and fro"  
port - starboard - port, or vice versa).

3. The factor "f" is of the greatest importance and the data from the above tests were used for assessing the influence of the distribution of the various masses in the whole body of the loaded ship.

4. For unloading fishing boats (but with fuel, stores and equipment), the following average values were observed:

	metric system	feet system
(a) double boom shrimp fishing boats	f ~0.95	f ~0.555
(b) deep sea fishing boats	f ~0.80	f ~0.445
(c) boats with a live fish well	f ~0.60	f ~0.335

The stated values are mean values. Generally, observed f-values were within ± 0.05 of those given above.

5. These f-values were based upon a series of limited tests and, therefore, Administrations should re-examine these in the light of any different circumstances applying to their own ships.

6. It must be noted that the greater the distance of masses from the rolling axis, the greater the rolling coefficient will be.

Therefore it can be expected that:

- the rolling coefficient for an unloaded ship, i.e. for a hollow body, will be higher than that for a loaded ship;
- the rolling coefficient for a ship carrying a great amount of bunkers and ballast - both groups are usually located in the double bottom, i.e. far away from the rolling axis - will be higher than that of the same ship having an empty double bottom.

7. The above recommended rolling coefficients were determined by tests with vessels in port and with their consumable liquids at normal working levels; thus, the influences exerted by the vicinity of the quay, the limited depth of water and the free surfaces of liquids in service tanks are covered.

8. Experiments have shown that the results of the rolling test method get increasingly less reliable the nearer they approach GM-values of 0.20 m. and below.

9. For the following reasons, it is not generally recommended that results be obtained from rolling oscillations taken in a seaway:

- (a) Exact coefficients for tests in open waters are not available.
- (b) The rolling periods observed may be not free oscillations but forced oscillations due to seaway.
- (c) Frequently, oscillations are either irregular or only regular for too short an interval of time to allow accurate measurements to be observed.
- (d) Specialized recording equipment is necessary.

10. However, it may be desirable to use the vessel's period of roll as a means of approximately judging the stability at sea. If this is done, care should be taken to discard readings which depart appreciably from the majority of other observations. Forced oscillations corresponding to the sea period and differing from the natural period at which the vessel seems to move should be disregarded. In order to obtain satisfactory results, it may be necessary to select intervals when the sea action is least violent, and it may be necessary to discard a considerable number of observations.

11. In view of the foregoing circumstances, it needs to be recognized that the determination of the stability by means of the rolling test in disturbed waters should only be regarded as a very approximate estimation.

12. The formula given in paragraph 2 can be reduced to

$$GM_o = \frac{F}{T_r^2}$$

and the Administration should determine the F value(s) for each vessel.

13. The determination of the stability can be simplified by giving the master permissible rolling periods, in relation to the draughts, for the appropriate value(s) of F considered necessary.

14. The initial stability may also be more easily determined graphically by using one of the attached sample nomograms for feet and/or metric units as described below:

- (a) The values for B and f are marked in the relevant scales and connected by a straight line (1). This straight line intersects the vertical line (mm) in the point (M).
- (b) A second straight line (2) which connects this point (M) and the point on the  $T_r$  scale corresponding with the determined rolling period, intersects the GM scale at the requested value.

15. The Appendix shows an example of a recommended form in which these instructions might be presented by each Administration to the Masters. It is considered that each Administration should recommend the F-value or values to be used.

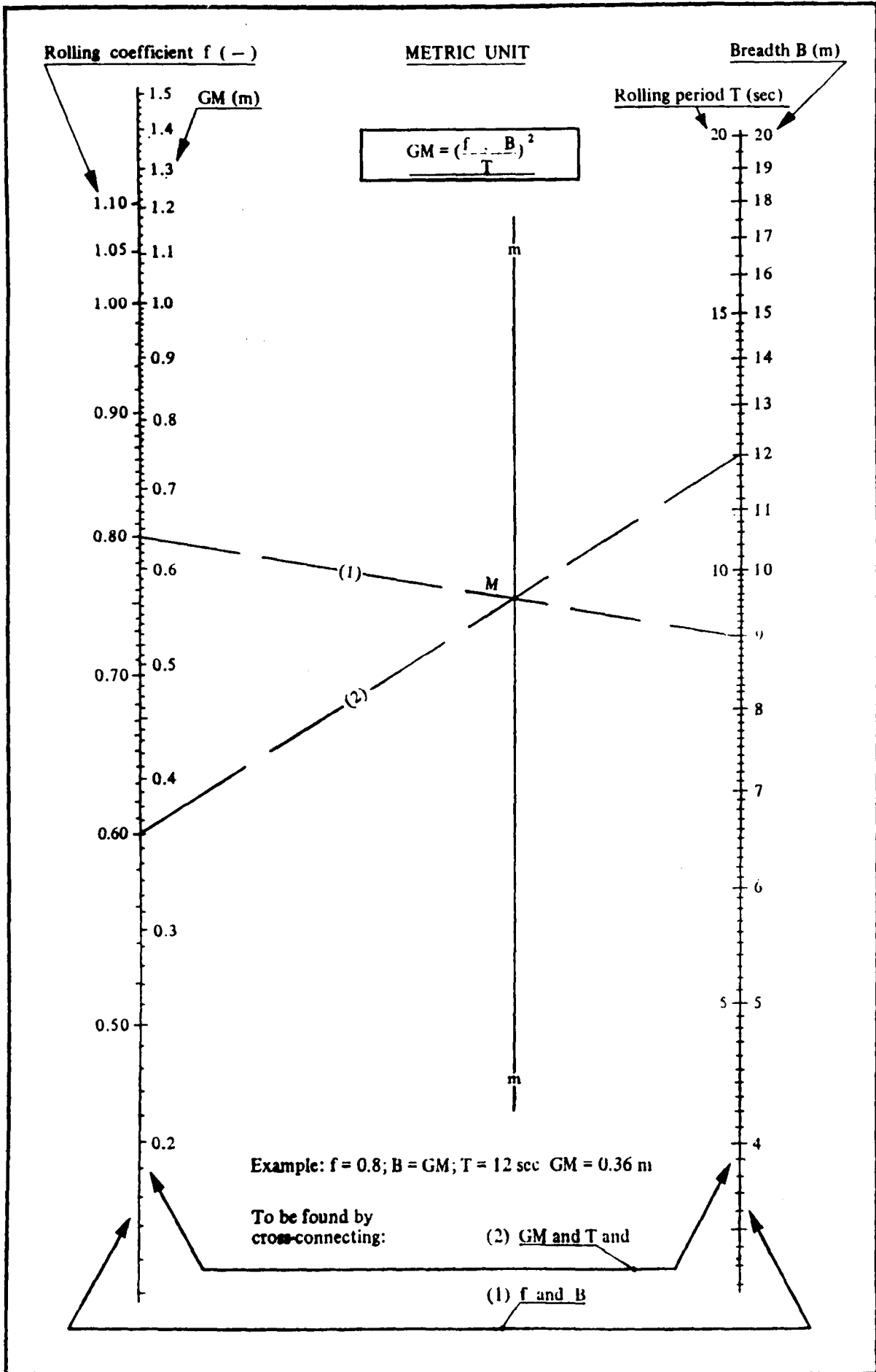

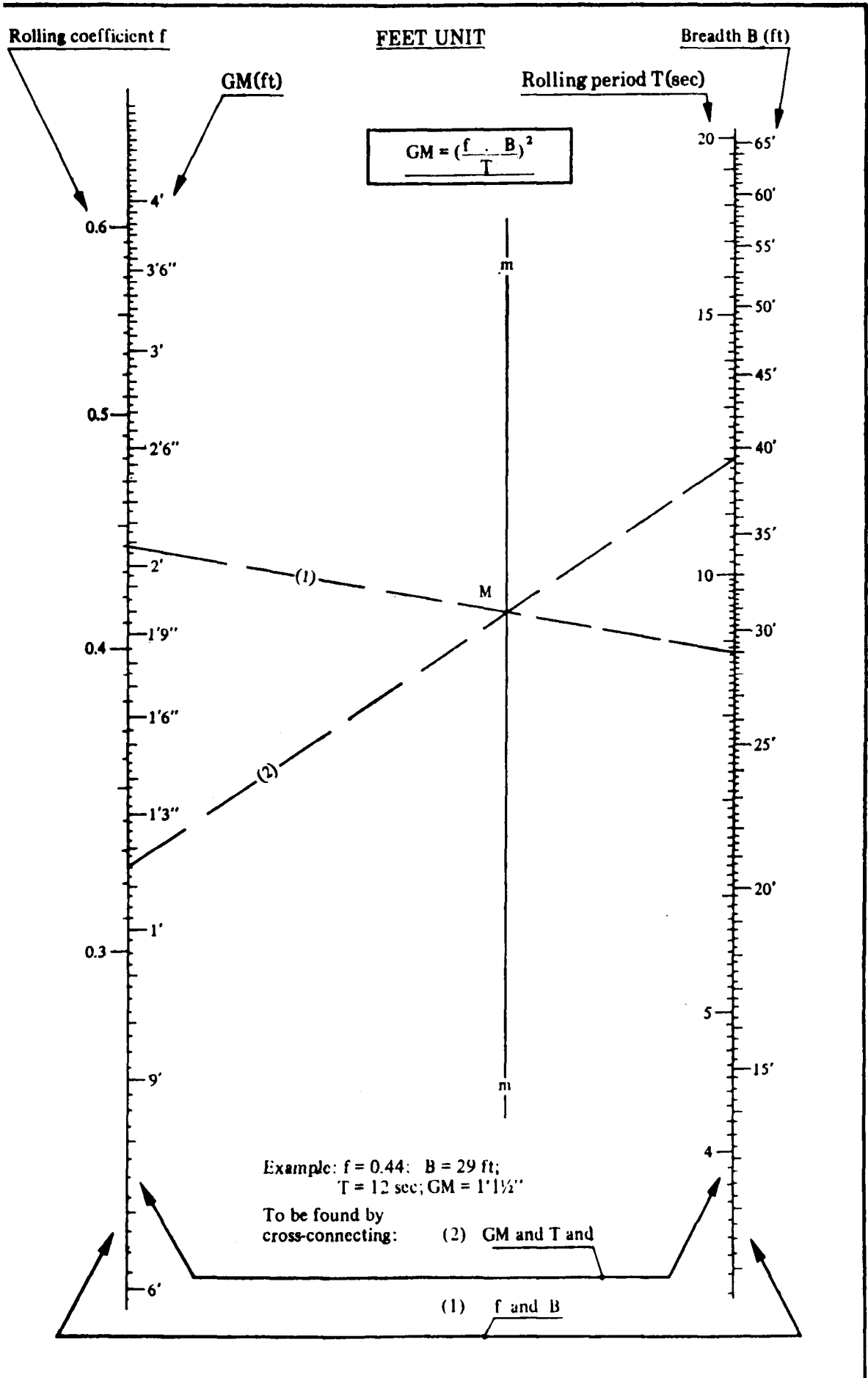

## APPENDIX

### SUGGESTED FORM OF GUIDANCE TO THE MASTER ON AN APPROXIMATE DETERMINATION OF SHIP'S STABILITY BY MEANS OF THE ROLLING PERIOD TEST

#### *Introduction*

1. If the following instructions are properly carried out, this method allows a reasonably quick and accurate estimation of the metacentric height, which is a measure of the ship's stability.
2. The method depends upon the relationship between the metacentric height and the rolling period in terms of the extreme breadth of the vessel.

#### *Test Procedure*

3. The rolling period required is the time for one complete oscillation of the vessel and to ensure the most accurate results in obtaining this value the following precautions should be observed:
  - (a) The test should be conducted with the vessel in harbour, in smooth water with the minimum interference from wind and tide.
  - (b) Starting with the vessel at the extreme end of a roll to one side (say port) and the vessel about to move towards the upright, *one complete oscillation* will have been made when the vessel has moved right across to the other extreme side (i.e. starboard) and returned to the original starting point and is about to commence the next roll.
  - (c) By means of a stop-watch, the time should be taken for not less than about 5 of these complete oscillations; the counting of these oscillations should begin when the vessel is at the extreme end of a roll. After allowing the roll to completely fade away, this operation should be repeated at least twice more. If possible, in every case the same number of complete oscillations should be timed to establish that the readings are consistent, i.e. repeating themselves within reasonable limits. Knowing the total time for the total number of oscillations made, the mean time for one complete oscillation can be calculated.
  - (d) The vessel can be made to roll by rhythmically lifting up and putting down a weight as far off middle-line as possible; by pulling on the mast with a rope; by people running athwartships in unison; or by any other means. However, and this is most important, as soon as this forced rolling has commenced the means by which it has been induced must be stopped and the vessel allowed to roll freely and naturally. If rolling has been induced by lowering or raising a weight it is preferable that the weight is moved by a dockside crane. If the ship's own derrick is used, the weight should be placed on the deck, at the middle-line, as soon as the rolling is established.
  - (e) The timing and counting of the oscillations should only begin when it is judged that the vessel is rolling freely and naturally, and only as much as is necessary to accurately count these oscillations.

- (f) The mooring should be slack and the vessel "breasted off" to avoid making any contact during its rolling. To check this, and also to get some idea of the number of complete oscillations that can be reasonably counted and timed, a preliminary rolling test should be made before starting to record actual times.
- (g) Care should be taken to ensure that there is a reasonable clearance of water under the keel and at the sides of the vessel.
- (h) Weights of reasonable size which are liable to swing, (e.g. a lifeboat), or liable to move (e.g. a drum), should be secured against such movement. The free surface effects of slack tanks should be kept as small as is practicable during the test and the voyage.

*Determination of the Initial Stability*

4. Having calculated the period for one complete oscillation, say T seconds, the metacentric height  $GM_0$  can be calculated from the following formula:

$$GM_0 = \frac{F}{T^2}$$

where F is ...  $\left[ \begin{array}{l} \text{to be determined for each particular vessel by the} \\ \text{Administration} \end{array} \right]$ .

5. The calculated value of  $GM_0$  should be equal to or greater than the critical value which is ...  $\left[ \begin{array}{l} \text{to be determined for each particular vessel by the} \\ \text{Administration} \end{array} \right]$ .

*Limitations to the Use of this Method*

6. A long period of roll corresponding to a  $GM_0$  of 0.20 m. or below, indicates a condition of low stability. However, under such circumstances, accuracy in determination of the actual value of  $GM_0$  is reduced.

7. If, for some reason, these rolling tests are carried out in open, deep but smooth waters, inducing the roll, for example, by putting over the helm, then the  $GM_0$  calculated by using the method and coefficient of paragraph 3 above should be reduced by  $\left[ \begin{array}{l} \text{figure to be estimated by the Administration} \end{array} \right]$  to obtain the final answer.

8. The determination of stability by means of the rolling test in disturbed waters should only be regarded as a very approximate estimation. If such test is performed, care should be taken to discard readings which depart appreciably from the majority of other observations. Forced oscillations corresponding to the sea period and differing from the natural period at which the vessel seems to move should be disregarded. In order to obtain satisfactory results, it may be necessary to select intervals when the sea action is least violent, and it may be necessary to discard a considerable number of observations.

APPENDIX V

RECOMMENDED PRACTICE ON PORTABLE FISH-HOLD  
DIVISIONS

1. Recognizing the desirability of ensuring the adequate strength of scantlings of portable fish-hold divisions, studies on national practices have been carried out, resulting in the establishment of certain formulae for scantlings, which are recommended to Administrations for their guidance.

2. These formulae represent the average of a wide range of experience covering all types of vessels operating in all sea areas, and in conditions likely to impose the maximum loading on a division. Alternative scantlings might, however, be accepted where experience has shown that these are more appropriate.

3. According to the basic type of construction, the following formulae are recommended for vertical fish-hold divisions:

(a) *Vertical steel uprights and horizontal wooden boards*

Minimum section modulus of vertical steel uprights

$$Z = 4psbh^2$$

Minimum thickness of horizontal wooden boards

$$t = \sqrt{8psb^2}$$

(b) *Horizontal steel beams and vertical wooden boards*

Minimum section modulus of horizontal steel beams

$$Z = 4psHS^2$$

Minimum thickness of vertical wooden boards

$$t = \sqrt{3.6psh^2}$$

where in the above formulae:

Z = section modulus, - cm<sup>3</sup>.

t = thickness of wooden board, - cm.

p = density of cargo, - ts/m<sup>3</sup>.

s = maximum transverse distance between any two adjacent longitudinal divisions or line of supports, - m.

h = maximum vertical span of a column taken to be the hold depth, - m.

b = maximum longitudinal distance between any two adjacent transverse divisions or line of supports, - m.

H = vertical span of a division which is supported by a horizontal beam, - m.

S = horizontal distance between adjacent points of support of a horizontal beam, - m.

4. In applying the above formulae, the following notes should be observed:
- (a) The formulae are applicable to longitudinal divisions. Where the divisions are athwartships the formulae should be modified by interchanging  $s$  and  $b$ .
  - (b) The formulae were derived on the assumption that the loads were on one side only of the divisions. When it is known that the divisions will always be loaded on both sides, reduced scantlings may be accepted.
  - (c) If vertical steel uprights are permanent and well connected at both ends with the structure of the ship, reduced scantlings may be accepted depending upon the degree of security provided by the end connections.
  - (d) In the formula for vertical wooden boards the full depth of the hold is assumed as the unsupported span, where the span is less the thickness may be calculated using the reduced span.
  - (e) The timber used should be of sound durable quality, of a type and grade which has proved satisfactory for fish-hold divisions and the actual finished thicknesses of boards should be those derived from the formulae. The thickness of boards made from good quality hardwood may be reduced by 12.5 per cent.
  - (f) Divisions made of other materials should have strength and stiffness equivalent to those associated with the scantlings recommended for wood and steel having regard to the comparative mechanical properties of the materials.
5. Figures 1 and 2 illustrate the application of the formulae.



HORIZONTAL WOOD BOARDS - STEEL UPRIGHTS

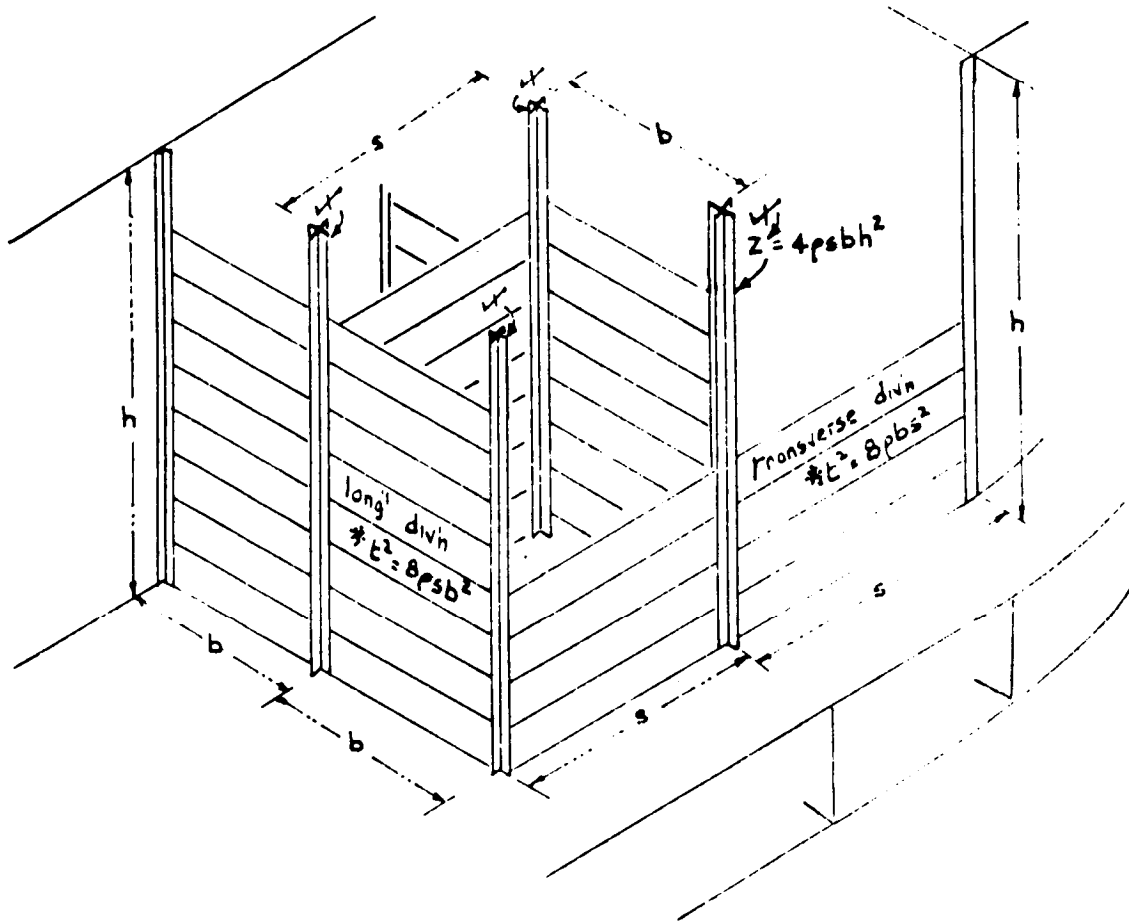

\*

Note: When the longitudinal and transverse divisional boards are interchangeable  $b$  will equal  $s$  and the thickness by either formula will be the same.  
If the boards are required to be of equal thickness but varying span the greater thickness should be used for all the boards when the section modulus is kept constant for all the uprights.

Fig.1

VERTICAL WOOD BOARDS - STEEL BEAMS

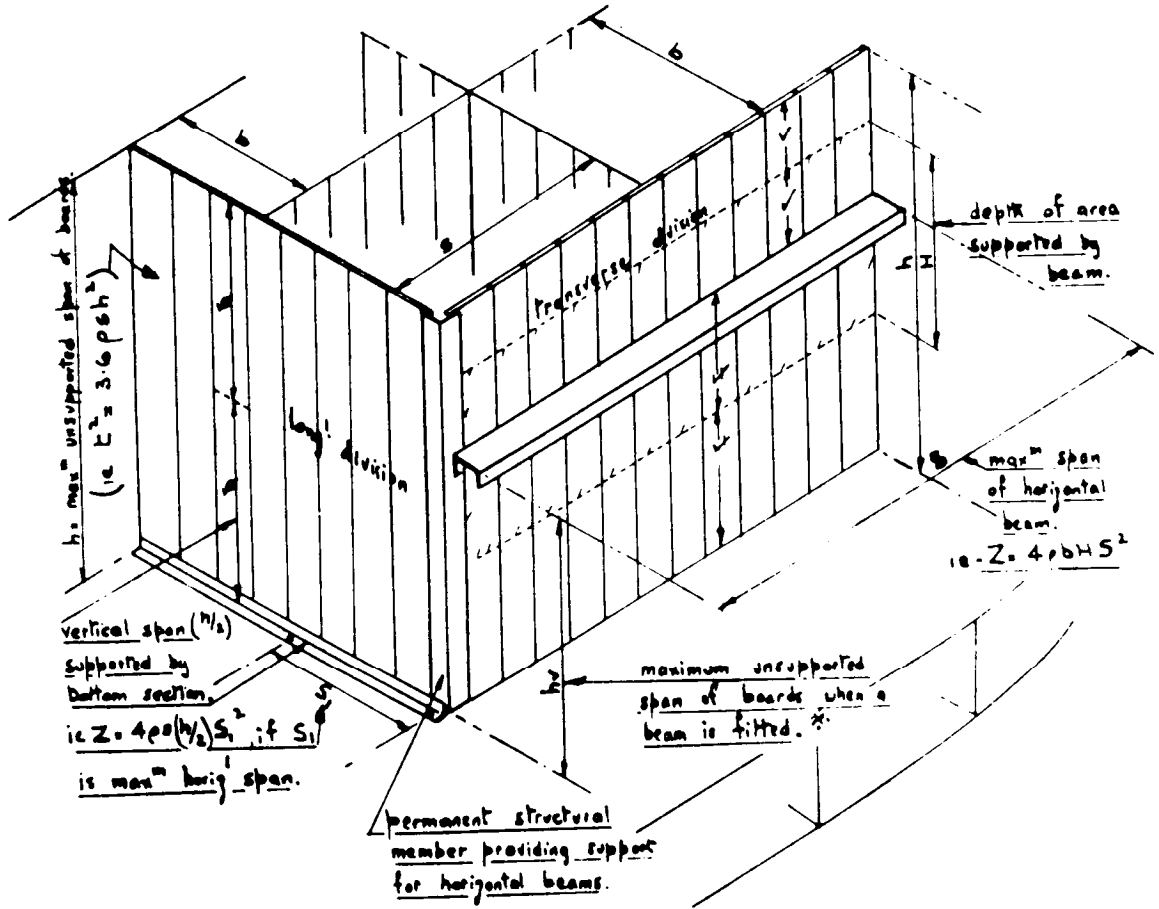

⊗ Note: If no beam was fitted the thickness of the vertical wood planks would be given by  $t^2 = 3.6pbh^2$ . The beam reduces the maximum span to  $h_v$  and the thickness is now given by  $t_1^2 = 3.6pbh_v^2$  or  $t_1 = t(\frac{h_v}{h})$ .

Fig.2

## APPENDIX VI

### RECOMMENDED PRACTICE FOR FREEING PORTS ON FISHING VESSELS

1. The following minimum areas are recommended for new decked fishing vessels intended for operating in unlimited waters in weather of unlimited severity.
2. On vessels where bulwarks on weather parts of the upper deck form wells, the minimum freeing port area (a) on each side of the ship for each well on the upper deck should be that given by the following formulae:

where the length of bulwark ( $\ell$ ) in the well is 20 metres or less

$$A = 0.7 + 0.035\ell \text{ square metres,}$$

where  $\ell$  exceeds 20 metres

$$A = 0.07\ell \text{ square metres}$$

$\ell$  need in no case be taken as greater than 0.7 L. If the bulwark is more than 1.2 metres in average height the required area should be increased by 0.004 square metres per metre of the length of well for each 0.1 metre difference in height. If the bulwark is less than 0.9 metre in average height, the required area may be decreased by 0.004 square metre per metre of length of well for each 0.1 metre difference in height.

3. The freeing port area should be so arranged along the length of the vessel as to provide the most rapid and effective freeing the deck of water. The lower edges of the freeing ports should be as near the deck as practicable.
4. Devices for locking freeing port covers should be considered generally as dangerous. If locking devices in particular cases are considered necessary for the service of the ship, they should be of a reliable type operable from a readily accessible position. In vessels intended to operate in areas subject to icing, it is recommended not to fit covers.
5. Administrations may permit alterations of the stated values where operating experience has clearly shown that such alterations are justified.

## APPENDIX VII

### RECOMMENDED PRACTICE FOR EXTERIOR HATCH COAMINGS AND DOOR SILLS ON FISHING VESSELS

1. Hatchway coamings and door sill heights should comply with the following standards:
  - (a) On upper decks to be at least 600 mm. However, in locations on the upper deck which are shielded from the full force of the sea, (with the exception of doors giving direct access to engine rooms), these heights may be reduced to 400 mm.

- (b) On superstructure decks to be at least 300 mm. However, in locations on the superstructure deck which are shielded from the full force of the sea, (with the exception of doors giving direct access to engine rooms), these heights may be reduced to 150 mm.
  - (c) A restricted number of small watertight scuttles on upper decks and watertight hatches on superstructure decks may be fitted without sills but these must be found essential for fishing operations.
2. This recommendation is applicable to all decked fishing vessels over 18 m. in length operating more than 15 miles from refuge in areas where a fully developed sea may occur which corresponds to Beaufort force 7 wind or greater.
  3. This recommendation is based on the premise that the construction of coamings, sills and closures is of sufficient strength to withstand the forces exerted by heavy seas without destroying the watertight integrity of the vessel.
  4. For vessels below 18 m. in length, for vessels operating up to 15 miles from a port of refuge, or for vessels operating in areas where a fully developed sea state seldom exceeds that corresponding to Beaufort force 7 wind, this recommendation should be applied as far as practicable..

#### APPENDIX VIII

##### SOME SUGGESTIONS TO FISHERMEN

The following measures should be considered as preliminary guidance on matters influencing safety of fishing vessels generally, and specifically as related to stability.

It is recommended that all fishermen be informed on these points in very simple language using terms and expressions readily understood by them even though most of the points should already be known by experienced fishermen.

It is further proposed that these suggestions should be included by fishery schools in their training of fishermen.

- (1) All doorways and other openings through which water can enter into the hull or deckhouses, forecastle, etc. shall be suitably closed in adverse weather conditions and accordingly all appliances for this purpose shall be maintained on board and in good condition.
- (2) Hatchcovers and flush deck scuttles should be kept properly secured when not in use during fishing.
- (3) All portable deadlights should be maintained in good condition and securely closed in bad weather.
- (4) All fishing gear and other large weights should be properly stowed and placed as low as possible.
- (5) Particular care should be taken when pull from fishing gear might have a bad effect on stability, e.g. when nets are hauled by power-block or the trawl catches obstructions on the seabed.

- (6) Gear for releasing deck load in fishing vessels carrying catch on deck, e.g. herring, should be kept in good working condition for use when necessary.
- (7) Freeing ports provided with closing appliances should always be capable of functioning and are not to be locked, especially in bad weather.
- (8) When the main deck is prepared for the carriage of deck load by division with pound boards, there should be slots between them of suitable size to allow easy flow of water to freeing ports to prevent trapping of water.
- (9) Never carry fish in bulk without first being sure that the portable divisions in the holds are properly installed.
- (10) At any one time keep the number of partially filled tanks to a minimum.
- (11) Observe any instructions given regarding filling of water-ballast tanks, but always remember that slack tanks can be dangerous.
- (12) Any closing devices provided for vent pipes to fuel tanks should be secured in bad weather.
- (13) Reliance on automatic or fixed steering is dangerous as this prevents speedy manoeuvring which may be needed in bad weather.
- (14) Be alert to all the dangers of following or quartering seas. If excessive heeling or yawing occurs, reduce speed as a first precaution.
- (15) In all conditions of loading necessary care should be taken to maintain a seaworthy freeboard.
- (16) Pay special attention to icing of a vessel and reduce it by all possible means.

28 November 1968  
Agenda item 9

RESOLUTION A.169(ES.IV)

Superseded by A.521(13)

#### RECOMMENDATION FOR TESTING LIFE-JACKETS

The Assembly,

*Noting* Article 16(i) of the Convention on the Inter-Governmental Maritime Consultative Organization concerning the functions of the Assembly,

*Bearing in mind* that at its present session it adopted the amendments to the International Convention for the Safety of Life at Sea, 1960, and in particular to Regulation 22 of Chapter III,

*Having considered* the Recommendation adopted by the Maritime Safety Committee at its seventeenth session,

*Adopts* the Recommendation for Testing Life-jackets, the text of which is set out in the Annex to this Resolution,

*Invites* all governments concerned to apply the provisions of this Recommendation when testing life-jackets for approval.