

Resolution A.685(17)
Adopted on 6 November 1991
(Agenda item 10)

**WEATHER CRITERION FOR FISHING VESSELS
OF 24 METRES IN LENGTH AND OVER**

THE ASSEMBLY,

RECALLING Article 15(j) of the Convention on the International Maritime Organization concerning the functions of the Assembly in relation to regulations and guidelines concerning maritime safety,

RECALLING ALSO resolution A.168(ES.IV) entitled "Recommendation on Intact Stability of Fishing Vessels",

NOTING that in resolution A.167(ES.IV) the Maritime Safety Committee had been requested to continue studies on improved stability criteria,

NOTING ALSO recommendation 1 of the International Conference on Safety of Fishing Vessels, 1977, regarding guidance on a method of calculation of the effect of severe wind and rolling in associated sea conditions contained in attachment 3 to the Final Act of the International Conference on Safety of Fishing Vessels, 1977,

RECOGNIZING the need to establish international standards for a weather criterion for fishing vessels of 24 metres in length and over,

HAVING CONSIDERED the recommendations made by the Maritime Safety Committee at its fifty-eighth session,

1. ADOPTS the Recommendation on Weather Criterion for Fishing Vessels of 24 metres in Length and Over set out in the annex to the present resolution;
2. NOTES that the weather criterion for fishing vessels of 45 metres in length and over is identical to the criterion for these vessels, as contained in resolution A.562(14);
3. INVITES Governments to take steps to give effect to the annexed Recommendation as soon as possible, unless they are fully satisfied that their national stability requirements supported by long operating experience ensure adequate stability for particular types and sizes of fishing vessels;
4. RESOLVES that the weather criterion contained in the annex to the present resolution supersedes that contained in attachment 3 to the Final Act of the International Conference on Safety of Fishing Vessels, 1977.

Annex

RECOMMENDATION ON WEATHER CRITERION FOR FISHING VESSELS OF 24 METRES IN LENGTH AND OVER

1 SCOPE

1.1 The criterion given hereunder is recommended for new decked seagoing fishing vessels of 24 m in length and above and applies to all loading conditions.

1.2 This criterion supplements the stability criteria of the Recommendation on Intact Stability of Fishing Vessels in resolution A.168(ES.IV). The more stringent criteria of resolution A.168(ES.IV) and the weather criterion of the present Recommendation should govern the minimum requirements.

1.3 Administrations are invited to adopt, in conjunction with other appropriate criteria, the weather criterion of the present Recommendation unless satisfied that experience justifies departures therefrom.

2 RECOMMENDED CRITERION

2.1 The ability of a ship to withstand the combined effects of beam wind and rolling should be demonstrated as follows for each standard condition of loading, with reference to figure 1:

- .1 The ship is subjected to a steady wind pressure acting perpendicular to the ship's centreline which results in a steady wind heeling lever (lw_1).
- .2 From the resultant angle of equilibrium (θ_0), the ship is assumed to roll owing to wave action to an angle of roll (θ_1) to windward. Attention should be paid to the effect of steady wind so that excessive resultant angles of heel are avoided.*
- .3 The ship is then subjected to a gust wind pressure which results in a gust wind heeling lever (lw_2).
- .4 Under these circumstances, area *b* should be equal to or greater than area *a*.
- .5 Free surface effects should be accounted for in the standard conditions of loading, e.g. according to appendix 1 to resolution A.168(ES.IV).

* The angle of heel under action of steady wind (θ_0) should be limited to a certain angle to the satisfaction of the Administration. As a guide, 16° or 80% of the angle of deck edge immersion, whichever is less, is suggested.

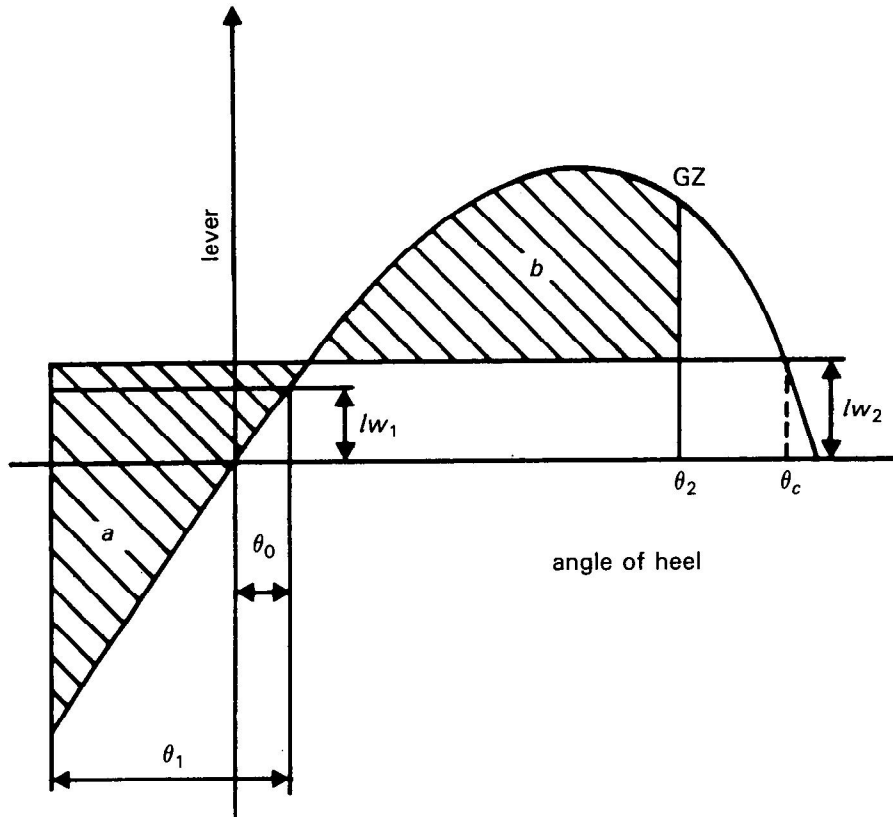

Figure 1 - Severe wind and rolling

The angles in the above figure are defined as follows:

θ_0 = angle of heel under action of steady wind (see 2.1.2 and footnote)

θ_1 = angle of roll to windward due to wave action

θ_2 = angle of downflooding (θ_f) or 50° or θ_c , whichever is less,

where:

θ_f = angle of heel at which openings in the hull, superstructures or deckhouses which cannot be closed weathertight immerse. In applying this criterion, small openings through which progressive flooding cannot take place need not be considered as open.

θ_c = angle of second intercept between wind heeling lever l/w_2 and GZ curves.

2.2 The wind heeling levers l/w_1 and l/w_2 referred to in 2.1.1 and 2.1.3 are constant values at all angles of inclination and should be calculated as follows:

$$l/w_1 = \frac{P \times A \times Z}{1000g\Delta} \text{ (m) and}$$

$$l/w_2 = 1.5l/w_1 \text{ (m)}$$

where:

$P = 504.2 \text{ N/m}^2$ * for fishing vessels of 45 m in length and over.

* The value of P used for ships in restricted service may be reduced subject to the approval of the Administration.

For fishing vessels of 24 m in length and over but less than 45 m values of P should be taken from table 1.

Table 1

h (m)	1	2	3	4	5	6 and over
P (N/m ²)	315.5	386.1	429.2	459.7	485	504.2

A = projected lateral area of the portion of the ship and deck cargo above the waterline (m²)

Z = vertical distance from the centre of A to the centre of the underwater lateral area or approximately to a point at one half the draught (m)

h = vertical distance from the centre of the projected lateral area of the ship above waterline to the waterline

Δ = displacement (t)

g = 9.81 m/s²

2.3 The angle of roll (θ_1),* referred to in 2.1.2, should be calculated as follows:

$$\theta_1 = 109k \times X_1 \times X_2 \sqrt{rs} \text{ (degrees)}$$

where:

X_1 = factor as shown in table 2

X_2 = factor as shown in table 3

k = factor as follows:

$k = 1.0$ for a round-bilged ship having no bilge or bar keels

$k = 0.7$ for a ship having sharp bilges

$k =$ as shown in table 4 for a ship having bilge keels, a bar keel or both

$$r = 0.73 \pm 0.6OG/d$$

with: OG = distance between the centre of gravity and the waterline (m) (+ if centre of gravity is above the waterline, - if it is below)

d = mean moulded draught of the ship (m)

s = factor as shown in table 5.

Table 2
Values of factor X_1

B/d	X_1
≤2.4	1.0
2.5	0.98
2.6	0.96
2.7	0.95
2.8	0.93
2.9	0.91
3.0	0.90
3.1	0.88
3.2	0.86
3.3	0.84
3.4	0.82
≥3.5	0.80

Table 3
Values of factor X_2

C_B	X_2
≤0.45	0.75
0.50	0.82
0.55	0.89
0.60	0.95
0.65	0.97
≥0.70	1.0

Table 4
Values of factor k

$\frac{A_k \times 100}{L \times B}$	k
0	1.0
1.0	0.98
1.5	0.95
2.0	0.88
2.5	0.79
3.0	0.74
3.5	0.72
≥4.0	0.70

Table 5
Values of factor s

T	s
≤6	0.100
7	0.098
8	0.093
12	0.065
14	0.053
16	0.044
18	0.038
≥20	0.035

(Intermediate values in tables 1 to 5 should be obtained by linear interpolation.)

* The angle of roll for ships provided with antirolling devices should be determined without taking into account the operation of these devices.

$$\text{Rolling period } T = \frac{2C \times B}{\sqrt{GM}} \text{ (seconds)}$$

where: C = rolling period factor* for $L < 45$ m

or: $C = 0.373 + 0.023(B/d) - 0.043(L/100)$ for $L \geq 45$ m

The symbols in the above tables and formula for the rolling period are defined as follows:

L = waterline length of the ship (m)

B = moulded breadth of the ship (m)

d = mean moulded draught of the ship (m)

C_b = block coefficient

A_k = total overall area of bilge keels, or area of the lateral projection of the bar keel, or sum of these areas (m²)

GM = metacentric height corrected for free surface effect (m).

*For fishing vessels less than 45 m in length, the C factor can be found in the *Code of Safety for Fishermen and Fishing Vessels - Part B*. Furthermore, the C factor data for various types and loading conditions of smaller fishing vessels may be known by the Administration. For a specific fishing vessel, the C factor considered the most appropriate should be used.

For fishing vessels greater than or equal to 45 m in length, or if no C data are available or if they are considered inappropriate, then the equation for the C factor given in resolution A.562(14) should be used (see equation above).

Resolutions and Other Decisions of the Seventeenth Assembly

(Publication No. IMO-142E)

ERRATA

Page

Resolution A.684(17)

36 *Paragraph 4.1:* For “damaged stability calculations” read “damage stability calculations”.

46 *Figure A-3:* For “B₁”, “B₂”, “B₃” read “b₁”, “b₂”, “b₃”, respectively.

47 *Table A-3:* In the bottom left-hand box, first line, for “2 and W2,3” read “1 and W2,3”.
In the bottom middle box, second line, for “ $p_{2.5} - r_{2.5}$ ” read “ $p_{2.5} \times r_{2.5}$ ”.

Table A-4: In the bottom middle box, second line, for “ $p_2(1-r_2)$ ” read “ $p_3(1-r_3)$ ”.

48 *Table A-5:* In the bottom middle box, second line,

for “ $p_{2.4} \times r_{2.4} - p_{2.4} - r_{2.4} - p_{3.4} \times r_{3.4}$ ”
read “ $p_{2.6} \times r_{2.6} - p_{2.4} \times r_{2.4} - p_{3.6} \times r_{3.6}$ ”.

In the bottom right-hand box, second line, for “ $X_2 = l_{1.4}$ ” read “ $X_2 = l_{1.6}$ ”.

55 *Figure A-9:* The title of the figure should read “Interpretation of longitudinal subdivision (in all instances, $v = 1$)”.

Resolution A.685(17)

61 *Paragraph 2.2:* The formula for lw_2 should read “ $lw_2 = 1.5/w_1$ (m)”.

Resolution A.686(17)

71 *Table 6.1.1:* In the bottom right-hand box, for “navigating” read “navigating bridge”.

85 *Table 9.1.7:* In the third column, second line (i.e. alarms/indicators required under SOLAS II-2/62.16.1.1 and 62.16.2), for “Inner gas pressure” read “Inert gas pressure”.

Resolution A.689(17)

104 and 105 *Figures 1 and 2:* The caption concerning dimensions for lifejackets should read:

- C - Cylinder
 - 125 mm diameter for adult sizes
 - 50 mm diameter for child sizes
- L - Test load