

Res. A. 652(16)

RESOLUTION A.652(16)

Adopted on 19 October 1989

Agenda item 10

**RECOMMENDATION ON FIRE TEST PROCEDURES FOR
UPHOLSTERED FURNITURE**

THE ASSEMBLY,

RECALLING Article 15(j) of the Convention on the International Maritime Organization concerning the functions of the Assembly in relation to regulations and guidelines concerning maritime safety,

RECOGNIZING the need to provide internationally uniform test procedures for upholstered furniture, as specified in regulation II-2/3.23.6 of the International Convention for the Safety of Life at Sea, 1974, as amended,

HAVING CONSIDERED the recommendations made by the Maritime Safety Committee at its fifty-seventh session,

1. ADOPTS the Recommendation on Fire Test Procedures for Upholstered Furniture, the text of which appears in the Annex to the present resolution;
2. INVITES all Governments concerned to apply the Recommendation in determining compliance with the requirements for resistance to the ignition and propagation of flame specified in regulation II-2/3.23.6 of the International Convention for the Safety of Life at Sea, 1974, as amended;
3. REQUESTS the Maritime Safety Committee to continue, in due time, work on the development of further fire test procedures as well as smoke test and toxicity test procedures for circulation to Governments.

ANNEX

**RECOMMENDATION ON FIRE TEST PROCEDURES FOR
UPHOLSTERED FURNITURE**

**(Methods of test for the ignitability by smokers' materials
of upholstered composites for seating)**

1 SCOPE

This test procedure prescribes methods for assessing the ignitability of material combinations, e.g. covers and filling used in upholstered seating when subjected to either a smouldering cigarette or a lighted match as might be applied accidentally in the use of upholstered seats. It does not cover ignition caused by deliberate acts of vandalism.

2 DEFINITION

For the purposes of this test procedure the following definition applies.

Progressive smouldering. An exothermic oxidation not accompanied by flaming which is self-propagating, i.e., independent of the ignition source. It may or may not be accompanied by incandescence.

Note: In practice it has been found that there is usually a clear distinction between materials which may char under the influence of the ignition source but which do not propagate further (non-progressive) and those where smouldering develops in extent and spreads (progressive).

3 PRINCIPLE

The principle is to subject an assembly of upholstery materials arranged to represent, in stylized form, the join between the seat and back (or seat and arm) surfaces of a chair to two sources of ignition, one being a smouldering cigarette, and the other a flaming source approximating to the calorific output of a burning match.

4 HEALTH AND SAFETY OPERATORS

4.1 General

There is a considerable risk with these tests and precautions have to be taken.

4.2 Enclosure

For safety, the tests should be conducted in a suitable fume cupboard. If such a cupboard is not available, an enclosure should be constructed so that the tester is not exposed to the fumes (see clause 8).

4.3 Extinguishers

Accessible means of extinguishing the samples should be provided, for example a bucket of water, a fire blanket, or fire extinguisher.

5 APPARATUS

5.1 Test rig

A suitable test rig is illustrated in figures 1 and 2. It shall consist of two rectangular frames hinged together and capable of being locked at right angles to each other.

The frames shall be made from nominal 25 mm x 3 mm steel flat bar and shall securely hold expanded steel platforms set 6 ± 1 mm below the top edge of the frames.

Note: The size of the mesh of the expanded steel is not critical, but a mesh size across the diagonals of approximately 28 mm x 6 mm has been found to be suitable.

The internal width and height of the back frame shall be 450 ± 2 mm x 300 ± 2 mm and the width and depth of the base frame 450 ± 2 mm x 150 ± 2 mm. A standard edging section may be used around the expanded steel to give protection and greater rigidity.

Res. A.652(16)

The sides of the frame shall extend beyond the back of each frame to provide for the hinge holes and to form the back legs. The hinge rod shall be of nominal 10 mm diameter steel, continuous across the back of the rig, and its axis 22.5 ± 0.5 mm beyond the back member of each frame.

The frames shall be lockable at right angles by a bolt or pin through each of the pairs of members forming the back legs. The front legs may be welded across the front corners of the base frame. The height of the legs shall be such as to leave a gap not less than 50 mm high between the base frame and the supporting surface.

For the tests, the rig shall be sited within the enclosure (see 4.2) and the testing shall be performed in a substantially draught-free environment permitting an adequate supply of air.

5.2 Smouldering cigarette source

An untipped cigarette, complying with the following requirements, is needed:

length	68 mm approximately;
diameter	8 mm approximately;
mass	1 g nominal;
smouldering rate	12.0 ± 1.5 min/50 mm.

The smouldering rate shall be verified, as follows, on one sample from each batch of 10 cigarettes used.

Mark the cigarette, conditioned as described in 6.1, at 5 mm and 55 mm from the end to be lit. Light it as described in 8.2.1 and impale it horizontally in draught-free air on a horizontal wire spike inserted not more than 13 mm into the unlit end. Record the time taken to smoulder from the 5 mm mark to the 55 mm mark.

5.3 Butane flame ignition source

Note: This source has been designed to give a calorific output approximating to that of a burning match.

A burner tube consisting of a length of stainless steel tube (8.0 ± 0.1 mm outside diameter, 6.5 ± 0.1 mm internal diameter and 200 ± 5 mm in length) is connected by flexible tubing to a cylinder containing butane via a flowmeter, fine control valve, on-off valve (optional) and cylinder regulator providing an outlet pressure of 27.5 mbar*.

Note: Such steel tubing may be marketed as 5/16 in outside diameter, 0.028 in wall thickness. Where tubing of these dimensions is not readily available, stainless steel tubing of approximately similar dimensions may be used providing that the 50 mm length at the "flame" end of the tube is machined to the given sizes.

The flowmeter shall be precalibrated to supply a butane gas flow rate at 25°C of 45 ± 2 ml/min. The flexible tubing connecting the output of the flowmeter to the burner tube shall be 2.5 m to 3.0 m in length with an internal diameter of 7.0 ± 1.0 mm.

* 1 mbar = 102 N/m² = 0.1 kPa.

- Notes:**
1. Under these conditions, the flame height is approximately 35 mm. Any divergence from this height may be due to lack of equilibration of the butane gas with the environmental conditions specified for test. A sufficient length of tubing should be provided within the controlled environment ($23 \pm 7^\circ\text{C}$) to ensure that the butane achieves the required temperature before flow measurement.
 2. Butane/propane mixture may be used as fuel for the flame ignition source provided that the same calorific output as that prescribed in the paragraph above is maintained.

6 ATMOSPHERE FOR CONDITIONING AND TESTING

6.1 Conditioning

The materials to be tested and the cigarettes shall be conditioned immediately before the test for 72 h in indoor ambient conditions and then for at least 16 h in an atmosphere having a temperature of $20 \pm 5^\circ\text{C}$ and a relative humidity of $50 \pm 20\%$.

6.2 Testing

For testing, a substantially draught-free environment, having a temperature of 15°C to 30°C and a relative humidity of 20% to 70%, shall be used.

7 TEST PIECES

7.1 General

The test piece materials shall be representative of the cover, filling and any other components to be used in the final assembly.

7.2 Cover material and fabric interliner

The cover size needed for each test is $800 \pm 10 \text{ mm} \times 650 \pm 10 \text{ mm}$. The long dimension shall be cut parallel to the selvage. The cover may be constructed from smaller pieces of material provided that the resulting seams are not located within 100 mm of the area likely to be affected by the test.

The cover shall have triangular cut-outs 325 mm from one end on both sides. The cut-outs shall be so positioned that when assembled on the test rig the lie of any pile is down the back assembly and from the hinge to the front of the base frame. The size of these cut-outs shall be approximately 50 mm base and 110 mm high.

Where a fabric interliner is used, it shall be cut to the same dimensions and in the same orientation as the cover for fitting to the test rig under the cover.

7.3 Upholstery filling

Two pieces, one $450 \pm 5 \text{ mm} \times 300 \pm 5 \text{ mm} \times 75 \pm 2 \text{ mm}$ thick, and the other $450 \pm 5 \text{ mm} \times 150 \pm 5 \text{ mm} \times 75 \pm 2 \text{ mm}$ thick are required for each test.

Some cushioning assemblies may consist of several layers that may be typically felt, wadding or different foams. In these cases the test pieces shall reproduce the upper 75 mm of the cushioning assembly.

Where the filling is less than 75 mm thick, the test piece shall be built up to the required thickness by adding to the underside a further layer of the bottom material.

8 TEST PROCEDURE

Warning

For safety, all tests should be carried out in a suitably constructed fume enclosure (see 4.2).

8.1 Preparation

8.1.1 Ensure that the means of extinguishment are close at hand (see 4.3).

8.1.2 Open out the test rig and thread the covering fabric and, if any, the fabric interliner behind the hinge bar.

8.1.3 Place the filling pieces under the covering fabric and, if any, the fabric interliner locating the filling pieces in the frame recesses, and allowing approximately 20 mm of fabric to wrap round the inside of the frames.

8.1.4 Lock the frames at right angles using the bolts or pins ensuring that the filling components are not displaced.

8.1.5 Fasten the fabric over the top, bottom and sides of the frame using clips and ensure that the fabric or fabrics are secured and under even tension.

8.2 Smouldering cigarette test

8.2.1 Light a cigarette (see 5.2) and draw air through it until the tip glows brightly. Not more than 8 mm of the cigarette shall be consumed in this operation.

8.2.2 Place the smouldering cigarette in position along the junction between the vertical and horizontal test pieces, allowing at least 50 mm from the nearest side edge, or from any marks left by any previous test, to the cigarette and simultaneously start the clock.

8.2.3 Observe the progress of combustion, and record any evidence of progressive smouldering (see clause 2) or flaming in the interior and/or cover.

Note: The detection of smouldering may be difficult and is made easier if a watch is kept for smoke emerging at points at a distance from the cigarette. Smoke is most easily viewed by looking down a rising column by means of a mirror.

8.2.4 If progressive smouldering or flaming of the upholstery components is observed at any time within a period of one hour of the placement of the cigarette, extinguish the test piece and record a fail result for the smouldering cigarette test.

8.2.5 If progressive smouldering or flaming is not observed within the one hour period, or if the cigarette fails to smoulder its complete length, repeat the test with a new cigarette placed in a fresh position not less than 50 mm from any previous test damage. If progressive smouldering or flaming is not observed in this retest, or if the cigarette fails to smoulder its complete length, record a pass result for the smouldering cigarette test unless the test piece fails the final examination specified in 8.4. Otherwise, extinguish the test piece and record a fail result.

Note: This repeat test may be run concurrently with the first test.

8.3 Butane flame test

8.3.1 Light the butane emerging from the burner tube, adjust the gas flow to the appropriate rate (see 5.3) and allow the flame to stabilize for at least 2 min.

8.3.2 Position the burner tube axially along the junction between the seat and back so that the flame is not less than 50 mm from the nearest side edge, or from any marks left by any previous test, and simultaneously start the clock.

8.3.3 Allow the gas to burn for a period of 20 ± 1 s, then terminate by carefully removing the burner tube from the test pieces.

8.3.4 Observe for flaming or progressive smouldering (see clause 2) in the interior and/or cover. Disregard flames, afterglow, smoking or smouldering that cease within 120 s of the removal of the burner tube.

8.3.5 If flaming or progressive smouldering of the upholstery components is observed, extinguish the test piece. Record a fail result for the butane flame ignition source test.

8.3.6 If flaming or progressive smouldering is not observed, repeat the test at a fresh position, as described in 8.3.2. If flaming or progressive smouldering is not observed in this retest, record a pass result for the butane flame ignition source test unless the test piece fails the final examination specified in 8.4. Otherwise extinguish the test piece and record a fail result.

8.4 Final examination

Cases of progressive smouldering undetected from the outside have been reported. Immediately after completion of the test programme on the assembly, dismantle and examine it internally for progressive smouldering. If this is present, extinguish the test piece and record a fail result for the relevant test source. For safety reasons, ensure that all smouldering has ceased before the rig is left unattended.

APPENDIX A

Guidance notes

A.1 This test procedure prescribes methods for examining the ignitability, in defined circumstances, of an assembly of upholstery materials. These materials are combined together in a way intended to be generally representative of their end use in upholstered seating, and the ignition sources are a smouldering cigarette and a flame representing a burning match.

Thus, the potential ignitability of a particular cover, filling and interliner in combination can be assessed and this will allow the development of specifications concerned with ignition by smokers' materials. However, there are two important limitations, as follows:

- (a) The tests are concerned only with ignitability, and any controls of fire hazard have to consider, in addition, other aspects of fire performance such as rate of fire development, heat output, rate and quantity of smoke production and toxic gas evolution. Ideally, any attempts to reduce ignitability ought not to affect these other properties adversely.

- (b) The tests only measure the ignitability of a combination of materials used in upholstered seating and not of a particular finished item of furniture incorporating these materials. They give an indication of, but cannot guarantee, the ignition behaviour of the finished item of furniture. This limitation occurs because design features of the furniture can greatly affect its fire properties; any ignitability tests of a piece of furniture would therefore need to be carried out on the actual item and not on component materials or mock-ups. However, limited information on ignitability more specifically related to an intended design may be obtained, as indicated in A.2 and A.3.

A.2 This test procedure prescribes laboratory tests for an assembly of materials which will give general guidance on the ignitability of finished furniture, but where more specific information is required, or in critical areas of end use, the principles may be applied to complete items or components of furniture or to suitably modified test assemblies, some examples of which are given below. In such cases the sources of ignition described in 5.2 and 5.3 may be applied at positions which, as a general rule, correspond to those where the hazard of ignition occurs in use.

Example 1:

If a chair were to have a gap between the seat and back cushions, the placement of ignition sources in the angle of the test apparatus would be inappropriate. Instead, face ignition, where the sources are placed at the centre of the horizontal and vertical surfaces, would be more meaningful.

Example 2:

The test apparatus may be used to model the junction of any vertical and horizontal surfaces so that both arm and back constructions, if different, may be tested separately in conjunction with the seat.

Example 3:

The use of different materials in a back and seat of a chair may be reproduced in the test, two different cover fabrics being joined by sewing or staples behind the hinge bar.

Example 4:

If, in the final design, a loose cushion is to be placed on an upholstered seat platform, additional cigarette traps are produced between the loose cushion and the surrounding upholstery. This may be examined by constructing a loose cushion of the appropriate materials measuring $500 \pm 5 \text{ mm} \times 75 \pm 2 \text{ mm}$ to be placed on top of the horizontal surface of the normally assembled test arrangement.

A.3 Another way in which this test principle might be used is to give information about individual materials to be used in a combination. For example, the ability of a cover material to provide protection against ignition can be indicated by testing it in combination with a substrate of known flammability; standard non-flame-retardant flexible polyether foam with a density of about 22 kg/m^3 has been found to be suitable. Such information about the individual materials does not eliminate the need to test the actual combination, but it can help in the short-listing of material combinations and so reduce the overall amount of testing required.

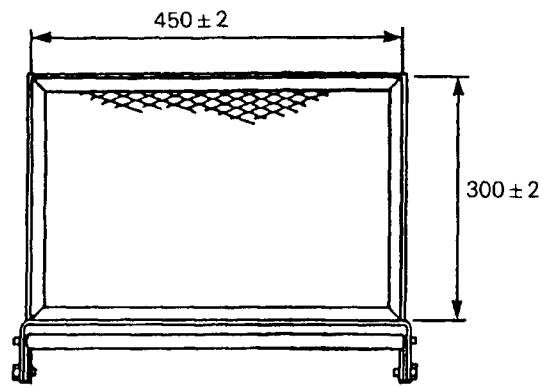

Front view
Scale 1:10

Unless tolerances are shown
dimensions are nominal

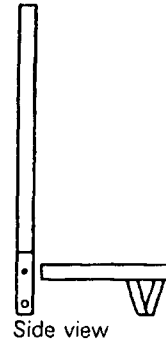

Side view

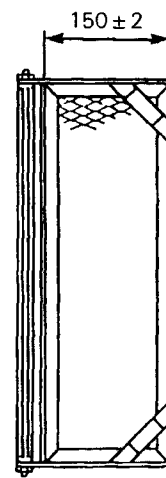

Inverted plan

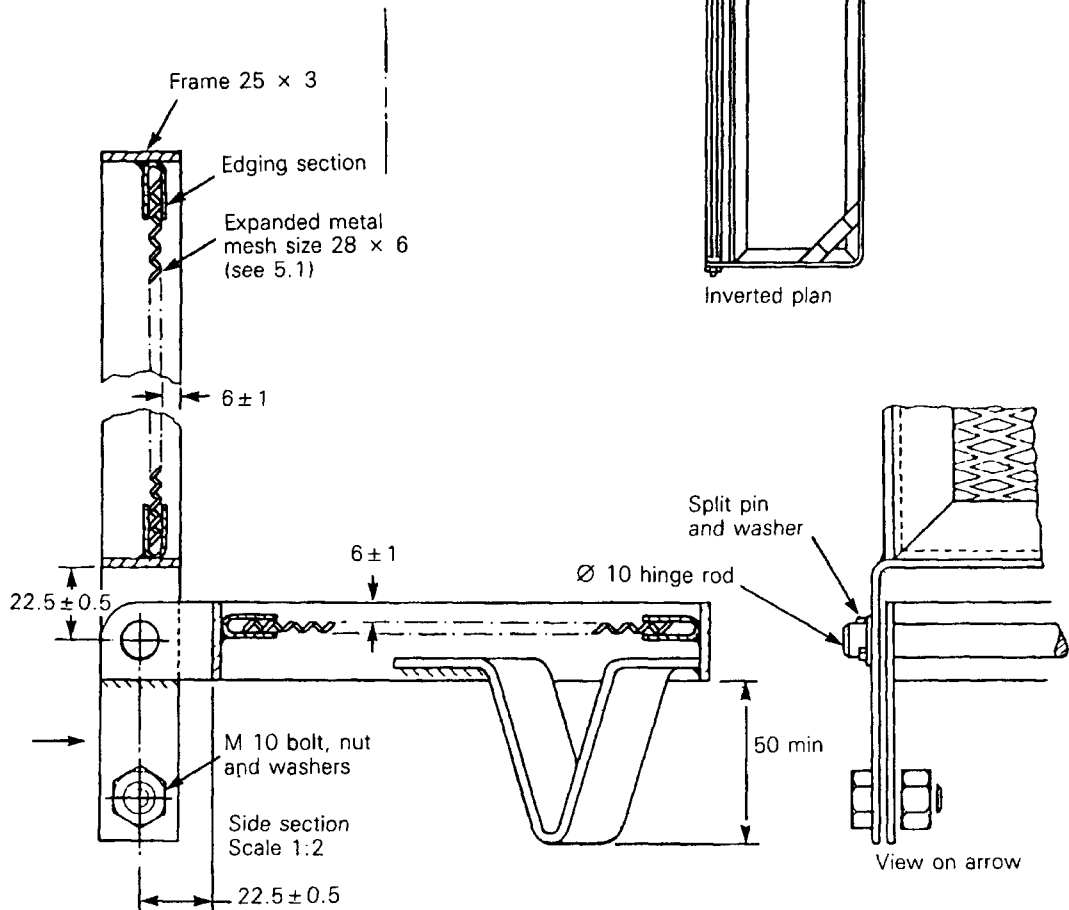

Figure 1 – Test rig

All dimensions are in millimetres. All parts are of steel.

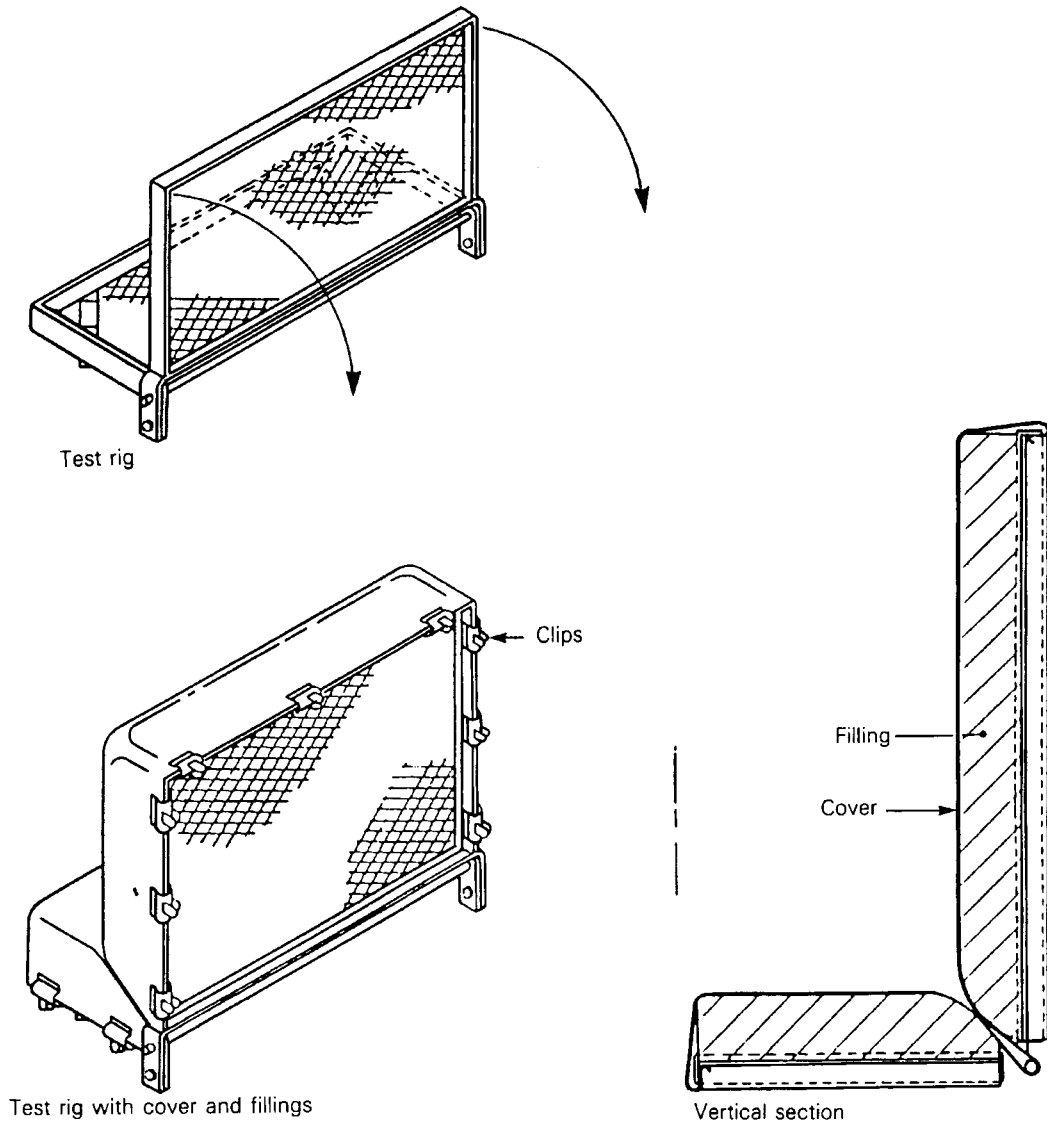

Figure 2 – Test rig assembly