

**RESOLUTION A.471(XII)**

Amended by [A.563\(14\)](#)

*Adopted on 19 November 1981  
Agenda item 10(b)*

**RECOMMENDATION ON TEST METHOD FOR DETERMINING THE  
RESISTANCE TO FLAME OF VERTICALLY SUPPORTED  
TEXTILES AND FILMS**

THE ASSEMBLY,

RECALLING Article 16(i) of the Convention on the Inter-Governmental Maritime Consultative Organization,

RECALLING FURTHER Recommendation 11 of the International Conference on Safety of Life at Sea, 1960, concerning test procedures for fire resisting and retarding divisions, deck coverings and flame-spread characteristics,

RECOGNIZING the need to provide internationally a uniform test method for determining the resistance to flame of vertically supported textiles and films, as specified in Regulation 3(s)(iii) of Chapter II-2 of the International Convention for the Safety of Life at Sea, 1974,

HAVING CONSIDERED the recommendations made by the Maritime Safety Committee at its forty-second and forty-fourth sessions,

1. ADOPTS the Recommendation on Test Method for Determining the Resistance to Flame of Vertically Supported Textiles and Films, the text of which appears in the Annex to the present resolution;
2. INVITES all Governments concerned to apply the recommendation in determining compliance with the requirements for the resistance to propagation of flame specified in Regulation 3(s)(iii) of Chapter II-2 of the International Convention for the Safety of Life at Sea, 1974;
3. REQUESTS the Maritime Safety Committee to continue in due time work on the development of further fire test procedures as well as smoke test and toxicity test procedures for circulation to Governments.

ANNEX

**RECOMMENDATION ON TEST METHOD FOR DETERMINING THE  
RESISTANCE TO FLAME OF VERTICALLY SUPPORTED  
TEXTILES AND FILMS**

1 SCOPE

This Recommendation specifies a procedure for qualifying textiles and films used primarily as vertically hanging curtains and draperies, as meeting the requirements for the resistance to propagation of flame specified in Regulation 3(s)(iii)\* of Chapter II-2 of the International Convention for the Safety of Life at Sea, 1974. Fabrics which are not inherently flame resistant should be exposed to cleaning or exposure procedures and tested both before and after such treatment.

---

\* Regulation II-2/3.23.6 of the 1981 amendments to the 1974 SOLAS Convention.

## 2 DEFINITIONS

**AFTERFLAME TIME.** The time during which the material continues to flame after the ignition source has been removed or extinguished.

**SUSTAINED IGNITION.** Afterflame time of 5 seconds or more.

**AFTERGLOW.** Persistence of glowing of a material after cessation of flaming or after the ignition source has been removed.

**SURFACE FLASH.** The rapid flash of a flame across the surface of the fabric primarily involving the surface pile finish and often leaving the base fabric in an essentially undamaged condition.

## 3 PURPOSE

The test method provides information on the ability of a fabric to resist sustained ignition and flame propagation when exposed to a small igniting flame. The performance of a fabric in this test does not necessarily indicate its resistance to flame propagation when exposed to conditions substantially different from those used in the test.

## 4 HEALTH AND SAFETY OF TEST OPERATORS

Burning of textiles may produce smoke and toxic gases which can affect the health of operators. The testing area should be cleared of smoke and fumes by suitable means of forced ventilation after each test, then restored to the required testing conditions.

## 5 TEST APPARATUS

5.1 Detailed drawings of both the test apparatus and enclosure for this test are available from the IMCO Secretariat.

### 5.2 Gas burner

A gas burner should be provided as illustrated in figure 1.\* This should be so mounted that the axis of the burner barrel is capable of adjustment to each of three fixed positions, viz. vertically upwards, horizontal or at an angle of 60° to the horizontal. The positions assumed by the burner with respect to the fabric are illustrated in figure 2.

### 5.3 Gas

Commercial grade propane of at least 95 per cent purity should be used.

### 5.4 Test enclosure

A 0.5 mm – 1.0 mm thick sheet metal draught shielding enclosure should be provided, measuring roughly 700 mm ± 25 mm x 325 mm ± 25 mm x 750 mm ± 25 mm high. The roof should be provided with 32 circular holes, each 13 mm ± 1 mm in diameter, symmetrically drilled, and baffled vent openings should be provided at the base of each side giving at least 32 cm<sup>2</sup> of free vent area, symmetrically distributed. One 700 mm x 325 mm face should be constructed to accommodate a closure door mainly of glass, and one smaller side should also be constructed as a vision panel. A hole should also be provided for the gas feed tube and remotely controlled burner positioning rod. The floor of the enclosure should be covered with a non-combustible insulating material. The interior should be painted black.

---

\* Figure 1 illustrates the burner as described in Deutsche Industrie Normen DIN 50 051 type KBN.

## 5.5 Specimen holder

A rectangular test frame, 200 mm  $\pm$  1 mm long x 150 mm  $\pm$  1 mm wide should be provided, constructed of stainless steel, 10 mm wide by 2 mm thick. Mounting pins incorporating distance stubs constructed of stainless steel 2.00 mm  $\pm$  1.00 mm diameter, should be fixed at each corner of the test frame and at the centre of both long members.

## 5.6 Base support

The test frame should be supported over a rigid metal base by means of two vertical uprights to which the frame may be attached. The metal base also provides a support for pivoting the burner pedestal to move the burner flame into contact with or away from the specimen.

# 6 TEST SPECIMENS

## 6.1 Preparation

The specimens should be as representative as possible of the material provided and should exclude selvages. At least ten specimens should be cut, each measuring 220 mm x 170 mm, five in the direction of the warp, five in the direction of the weft. Where the fabric has differing surfaces on the two sides enough samples should be cut for both surfaces to be tested.

Using a template 220 mm x 170 mm, with holes approximately of 5 mm diameter located on the template at the position of the pins on the frame, each specimen should be laid flat on a bench and premarked/punctured, to ensure a repeatable and reproducible tension of the specimen, after mounting on the frame.

## 6.2 Conditioning and exposure procedures

The specimens should be conditioned at 20°C  $\pm$  5°C and 65 per cent  $\pm$  5 per cent relative humidity for not less than 24 hours before test. If the material is not inherently flameproof, one of the exposure procedures detailed in Appendix 2 may, at the discretion of the approving authority, be applied to at least ten further specimens.

## 6.3 Mounting

Each sample should be removed from the conditioning atmosphere and either tested within three minutes or placed in a sealed container until required. The fabric should be mounted on the pins of the test frame in the locations previously marked on each fabric (see 6.1). The location of the fabric on the pins should be such that it is roughly centred in the width direction and the lower edge of the fabric extends 5 mm  $\pm$  1 mm below the lower pin.

# 7 TEST PROCEDURE

## 7.1 Presetting of the igniting flame

The gas burner should be ignited and preheated for at least two minutes. The fuel supply should then be adjusted so that, when the burner is in the vertical position, the distance between the tip of the burner tube and the visible tip of the flame is 40 mm  $\pm$  2 mm. If desired a gas flow meter may be used as a means of achieving reproducibility in adjusting the burner flame length.

## 7.2 Determining the mode of flame application for a given fabric

The angle of the burner should be adjusted to the horizontal position and the height fixed so that the flame, when the burner is in position, will impinge on the fabric at a central point, 40 mm above the level of the first row of pins. The door to the enclosure should then be closed and the burner moved into a position such that the burner tip is 17 mm from the face of the

specimen. The flame should be applied for five seconds and then removed. If no sustained ignition occurs a new specimen should be fixed to the holder and the flame applied as before but in this case for 15 seconds. Failure to achieve sustained ignition at the longer duration requires the position of the burner to be adjusted to a position such that the tip of the burner lies 20 mm below the bottom edge of the fabric, the flame impinging on it. The flame should be applied in this position to a new specimen for five seconds and if no sustained ignition occurs another specimen should be inserted and the time of flame application should be extended to 15 seconds. The ignition condition to be used for testing the specimens should be that at which sustained ignition is first achieved when the order of test listed above is followed. In the absence of sustained ignition the specimens should be tested under conditions showing the greatest char length. The method of flame application for warp and weft specimens should be determined using the ignition sequence given above.

### 7.3 Flame test

Using the burner position and flame application time found to be appropriate for the specimens under test, a further five samples cut in both warp and weft directions should be tested as described in 6.2 and the afterflame times noted. Any evidence of surface flash should be noted. If afterglow is observed to occur during a test the specimen should be allowed to remain in place until all glowing has ceased. The extent of char is also measured. Where doubt exists as to the precise limit of damaged fabric, the procedure detailed in Appendix 1 should be followed.

### 7.4 Flaming drops

To investigate if burning drops of thermoplastic materials are capable of igniting combustible materials on the base of the apparatus, cotton wool as specified in 3.5(2) of the Annex to resolution A.163(ES.IV) as amended by resolution A.215(VII)\* of the IMCO Assembly should be laid to a depth of 10 mm over the base plate, immediately below the specimen holder. Note should be made of any ignition or glowing of the cotton wool.

## 8 TEST REPORT

The test report should include the following information:

- .1 name of the testing authority;
- .2 name of the manufacturer of the material;
- .3 date of supply of the material and date of test;
- .4 name or identification mark of material;
- .5 description of material;
- .6 weight per unit area of material;
- .7 conditioning of samples and exposure procedures used, if any;
- .8 mode of flame application used;
- .9 duration of flame application;
- .10 afterflame, length of char and ignition of cotton waste from drops, as applicable;
- .11 type of cleaning and weathering procedures used, if any.

---

\* The cotton wool should consist of new, undyed and soft fibres without any admixtures or artificial fibres, and it should be free from thread, leaf and shell fibre dust. A suitable material for this purpose is packaged in the form of rolls for surgical use.

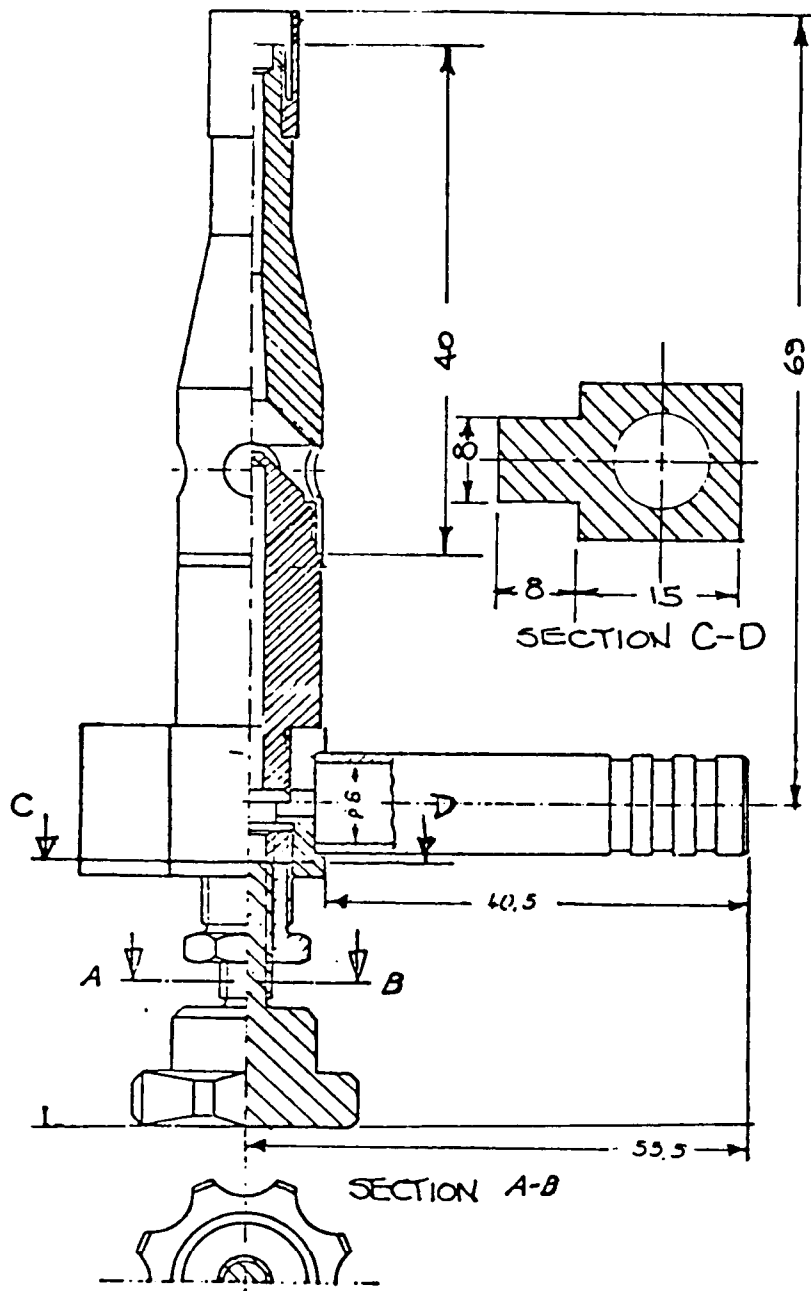
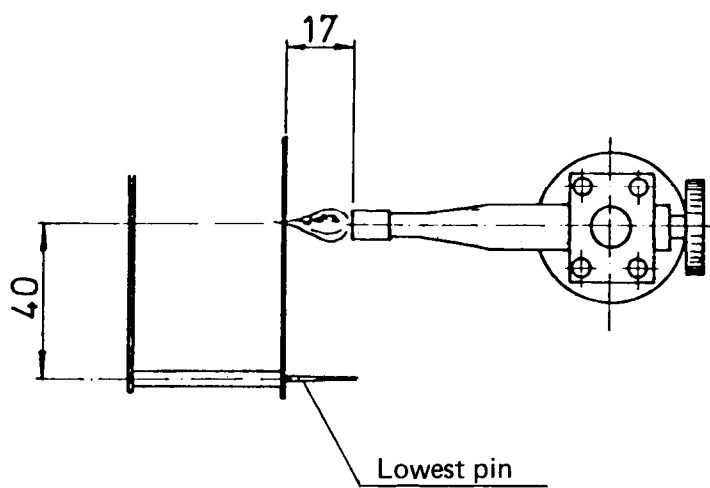

Figure 1 — Ignition burner\*

\* According to DIN 50 051 type KBN

### SURFACE IGNITION



### EDGE IGNITION

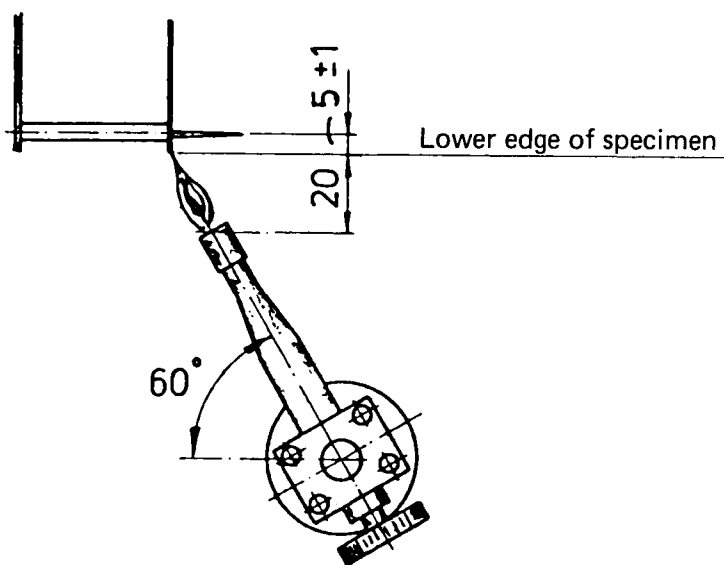

Figure 2 — Ignition burner — Fabric positions

APPENDIX 1

## MEASUREMENT OF LENGTH OF CHAR OR MATERIAL DESTRUCTION

## 1 APPARATUS

A hook and weight assembly should be used to determine the length of char or destruction of the specimen. The combined mass of the assembly should be as indicated in table 1:

TABLE 1

## Mass to tear charred fabric

Mass of fabric being tested	Total mass used to tear fabric
g/m <sup>2</sup>	g
< 200	100
200-600	200
> 600	400

## 2 METHOD

After all flaming and afterglow on the specimen have ceased, the length of char or material destruction should be determined immediately. The length of char in this test is defined as the distance from the end of the specimen which was exposed to the flame to the end of a tear made lengthwise in the specimen through the centre of the charred area in the following manner:

- .1 The edge of the highest or greatest char penetration of the sample should be inspected to determine if as a result of thermoplastic behaviour a thickening of the edge has developed as a result of the test. If this has occurred a cut should be made, after cooling, only sufficiently deep to cut through the highest portion of this thickened edge of the charred specimen.
- .2 The specimen should be folded parallel to its length and lightly creased through the maximum visible portion of the charred length.
- .3 The hook should be inserted in the specimen, on one side of the charred area, 8 mm in from the adjacent outside edge and 8 mm up from the bottom.
- .4 The specimen should then be grasped with the fingers on the opposite side of the charred area, and raised gently until it supports the weight. The specimen will tear through the charred area until fabric strong enough to carry the load is reached.

APPENDIX 2

## CLEANING AND WEATHERING PROCEDURES

## 1 GENERAL CONSIDERATIONS

1.1 It is assumed that any fabric intended for marine use will either have been subjected to a permanent fire retardant treatment or have been made from inherently flame resistant materials. This Appendix describes procedures intended to permit verification of this assumption.

## 2 APPLICATION

2.1 These procedures should be applied to fabrics.

2.2 Each fabric should be subjected to only those exposure procedures which are applicable to its intended use. It should meet the flame resistance requirements of section 5 after passing through the appropriate exposure cycles.

2.2.1 Accelerated exposure tests described in this Appendix should provide sufficient testing to permit a reasonable appraisal of the durability of the treatment (under the conditions for which it was designed) for the useful life of the fabric.

### 3 ACCELERATED DRY-CLEANING

3.1 The treated fabric should be dry-cleaned in a coin-operated dry-cleaning apparatus as part of a load made up with dummy pieces of dry-cleanable fabrics. The effective liquor ratio should be 1:10 or 10 kg of liquid per kilogram of fabric.

3.2 The coin-operated apparatus with perchloroethylene solvent (about 1 per cent charge system involving an emulsifying agent and water) should be run for the full cycle which includes tumble-drying. At the end of each dry-cleaning cycle, remove the load from the unit and separate the pieces.

3.3 The above dry-cleaning should be repeated until ten full cycles of cleaning and drying have been completed.

3.4 Test specimens should then be cut from the dry-cleaned fabric for testing.

### 4 ACCELERATED LAUNDERING

4.1 A sample of the treated fabric should be washed in an automatic commercial washing machine using a solution containing 0.5 per cent solution of IEC test detergent with perborate type 1\*. The liquor ratio used should be 1:15.

4.2 The operating cycle outlined in table 1 should be followed.

TABLE 1  
Operating cycle for accelerated laundering<sup>1</sup>

Operation	Time, minutes	Temperature, °C
1. Sudsing	6	55
2. Sudsing	6	70
3. Sudsing	6	70
4. Bleaching	8	70
5. Rinsing	2	70
6. Rinsing	2	70
7. Rinsing	2	70
8. Rinsing	2	55
9. Blueing	3	40
10. Hydroextraction	3	40

<sup>1</sup> This cycle is intended for white fabrics. For coloured fabrics, the bleaching and blueing operations are omitted and the temperature of the "sudsing" and "rinsing" operations is reduced by 17°C.

\* The formulation of this detergent is defined in IEC Publication 456 as amended in 1980.



4.3 The sample should then be dried in a tumbler-drier at a temperature of 80°C.

4.4 The above procedure should be repeated until ten full cycles of washing and drying have been completed.

4.4.1 If the material is to be subjected to a special use, more laundering may be required.

4.5 Where instructions for laundering a fabric are supplied by the manufacturer or finisher, those instructions should be followed in preference to the above procedure which simulates a typical commercial laundering practice.

## 5 ACCELERATED WATER LEACHING

5.1 A sample of the treated fabric should be totally submerged in a vessel containing tap water at room temperature for a period of 72 hours. The vessel should be capable of use with a liquor ratio of 1:20.

5.2 The water should be drained from the tank and replenished at 24-hour intervals during the immersion period.

5.3 At the conclusion of the immersion period, the sample should be removed from the test vessel and dried in a tumbler-drier or oven at a temperature of about 70°C.

## 6 ACCELERATED WEATHERING

6.1 Either a suitable accelerated weathering procedure using a xenon lamp or one of the following described procedures may be called for by the responsible Administration.

### 6.2 Alternative procedure No. 1.

#### 6.2.1 Apparatus:

- .1 the apparatus should consist of a vertical metal cylinder fitted with a vertical carbon arc at its centre and having a specimen holder mounted within;
- .2 the diameter of the cylinder should be such that the distance to the face of the specimen holder from the centre of the carbon arc is 375 mm;
- .3 the cylinder should be arranged to rotate about the arc at a rate of approximately one revolution per minute;
- .4 a water spray should be provided within the cylinder and fitted with means to regulate the amount of water discharged;
- .5 the vertical carbon arc should be either 13 mm diameter solid electrode type, if operating on direct current, or a single-cored electrode, if operating on alternating current. The electrodes should be of uniform composition;
- .6 the arc should be surrounded by a clear globe of quartz glass, 1.6 mm thick, or other enclosure having equivalent absorbing and transmitting properties.

#### 6.2.2 Operation of the test equipment:

- .1 the specimens for test should be mounted on the inside of the cylinder facing the arc;
- .2 the cylinder should rotate at approximately one revolution per minute for the duration of the test;
- .3 the water spray should discharge about 0.0026 m<sup>3</sup>/min on to the specimens for about 18 minutes during each 120-minute period;

- .4 the arc should operate on 13A direct current or 17A, 60 Hz alternating current, with voltage at the arc of 140V;
- .5 the electrodes should be renewed at intervals sufficiently frequent to ensure full operative conditions of the lamp;
- .6 the globe should be cleaned when the electrodes are removed or at least once in each 36 hours of operation.

6.2.3 Test cycle:

- .1 specimens should be subjected to this exposure for 360 hours;
- .2 specimens should then be allowed to dry thoroughly at a temperature of between 20° and 40° C;
- .3 after drying, the specimens should proceed through the flame test.

6.3 Alternative procedure No. 2

6.3.1 Apparatus:

- .1 the apparatus should consist of a vertical carbon arc mounted at the centre of a vertical cylinder;
- .2 a rotating rack should be mounted on the inside of the cylinder such that the distance from the face of the specimen to the centre of the arc is 475 mm;
- .3 the arc should be designed to accommodate two pairs of carbon electrodes No. 22 upper electrodes and No. 13 lower electrodes. However, the arc should burn between only one pair of electrodes at a time;
- .4 no filters or enclosures should be used between the arcs and the specimens;
- .5 spray nozzles should be mounted in the cylinder so that the specimens should be exposed to wetting for about 18 minutes during each 120-minute period.

6.3.2 Operation of test equipment:

- .1 the specimens for test should be mounted on the rotating rack, facing the arc;
- .2 the rack should rotate about the arc at a uniform speed of about one revolution per minute;
- .3 the arc should operate on 60A and 50V across the arc for alternating current or 50A and 60V across the arc for direct current.

6.3.3 Test cycle:

- .1 specimens should be subjected to this exposure for 100 hours;
- .2 they should then be allowed to dry thoroughly at a temperature of between 20° and 40° C;
- .3 after drying, the specimens should proceed through the flame test.

APPENDIX 3

## PROPOSED CRITERIA FOR CURTAINS AND DRAPES

The following criteria for classification of materials are recommended as guidance. Where a different application of the test method is desired, other criteria may be applicable.

1 Following application of the flame test the experimental data from the ten or more specimens should be examined. Products which show any of the following characteristics should be considered unsuitable for use as curtains, draperies, or free-hanging fabric product for use in rooms containing furniture and furnishings of restricted fire risk as defined in Regulation 3(s)(iii)\* of Chapter II-2 of the 1974 SOLAS Convention:

- .1 An afterflame time greater than five seconds for any of the ten or more specimens tested with surface application of the pilot flame. But see 2 below.
- .2 Burn through to any edge of any of the ten or more specimens tested with surface application of the pilot flame. But see 2 below.
- .3 Ignition of cotton wool below the specimen in any of the ten or more specimens tested. But see 2 below.
- .4 An average char length in excess of 150 mm observed in any of the batches of five specimens tested by either surface or edge ignition.
- .5 The occurrence of a surface flash propagating more than 100 mm from the point of ignition with or without charring of the base fabric. But see 2 below.

2 If, following analysis of the experimental data from tests of a fabric, it is found that either or both of the batches of five specimens cut in both warp and weft directions fail to meet one or more of the first three criteria because of poor performance of only one of the five specimens tested, one complete retest of a similar batch is permitted. Failure of the second batch to meet any of the criteria should provide the basis for rejection of the fabric for use.

---

\* Regulation II-2/3.23.6 of the 1981 amendments to the 1974 SOLAS Convention.